

ARULMIGU PALANIANDAVAR ARTS COLLEGE FOR WOMEN
PALANI
DEPARTMENT OF BOTANY



LEARNING RESOURCE
BIOINSTRUMENTATION

What is chromatography?

- Chromatography is an important biophysical technique that enables the separation, identification, and purification of the components of a mixture for qualitative and quantitative analysis.
- The Russian botanist Mikhail Tswett coined the term chromatography in 1906.
- The first analytical use of chromatography was described by James and Martin in 1952, for the use of gas chromatography for the analysis of fatty acid mixtures.
- A wide range of chromatographic procedures makes use of differences in size, binding affinities, charge, and other properties to separate materials.
- It is a powerful separation tool that is used in all branches of science and is often the only means of separating components from complex mixtures.

Principle of Chromatography (how does chromatography work)

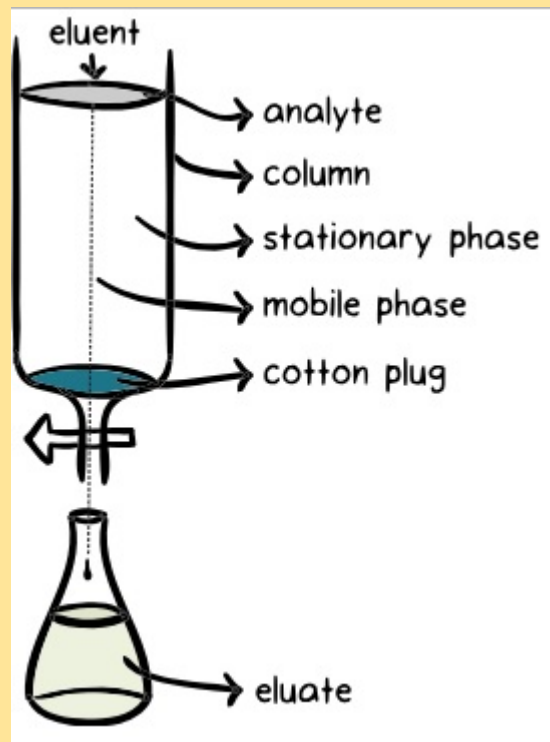

- Chromatography is based on the principle where molecules in mixture applied onto the surface or into the solid, and fluid stationary phase (stable phase) is separating from each other while moving with the aid of a mobile phase.
- The factors effective on this separation process include molecular characteristics related to adsorption (liquid-solid), partition (liquid-solid), and affinity or differences among their molecular weights.
- Because of these differences, some components of the mixture stay longer in the stationary phase, and they move slowly in the chromatography system, while others pass rapidly into the mobile phase, and leave the system faster.

Three components thus form the basis of the chromatography technique.

1. **Stationary phase:** This phase is always composed of a “solid” phase or “a layer of a liquid adsorbed on the surface solid support”.
2. **Mobile phase:** This phase is always composed of “liquid” or a “gaseous component.”
3. **Separated molecules**

The type of interaction between the stationary phase, mobile phase, and substances contained in the mixture is the basic component effective on the separation of molecules from each other.

Applications of Chromatography

Pharmaceutical sector

- To identify and analyze samples for the presence of trace elements or chemicals.
- Separation of compounds based on their molecular weight and element composition.
- Detects the unknown compounds and purity of mixture.
- In drug development.

Chemical industry

- In testing water samples and also checks air quality.
- HPLC and GC are very much used for detecting various contaminants such as polychlorinated biphenyl (PCBs) in pesticides and oils.
- In various life sciences applications

Food Industry

- In food spoilage and additive detection
- Determining the nutritional quality of food

Forensic Science

- In forensic pathology and crime scene testing like analyzing blood and hair samples of crime place.

Molecular Biology Studies

- Various hyphenated techniques in chromatography such as EC-LC-MS are applied in the study of metabolomics and proteomics along with nucleic acid research.
- HPLC is used in Protein Separation like Insulin Purification, Plasma Fractionation, and Enzyme Purification and also in various departments like Fuel Industry, biotechnology, and biochemical processes.

Types of Chromatography

The four main types of chromatography are

1. Adsorption Chromatography

In the process of adsorption chromatography, different compounds are adsorbed on the adsorbent to different degrees based on the absorptivity of the component. Here also, a mobile phase is made to move over a stationary phase, thus carrying the components with higher absorptivity to a lower distance than that with lower absorptivity. The main types of chromatographic techniques that are used in industries are given as under.

ADSORPTION CHROMATOGRAPHY

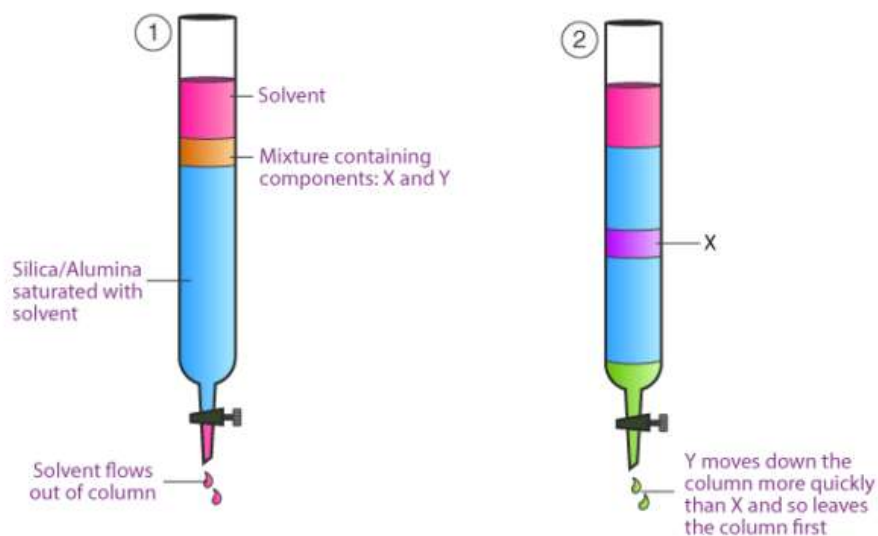

2. Thin Layer Chromatography

In the process of thin-layer chromatography (TLC), the mixture of substances is separated into its components with the help of a glass plate coated with a very thin layer of adsorbent, such as silica gel and alumina, as shown in the figure below.

The plate used for this process is known as chrome plate. The solution of the mixture to be separated is applied as a small spot at a distance of 2 cm above one end of the plate. The plate is then placed in a closed jar containing a fluid termed as an eluant, which then rises up the plate carrying different components of the mixture to different heights.

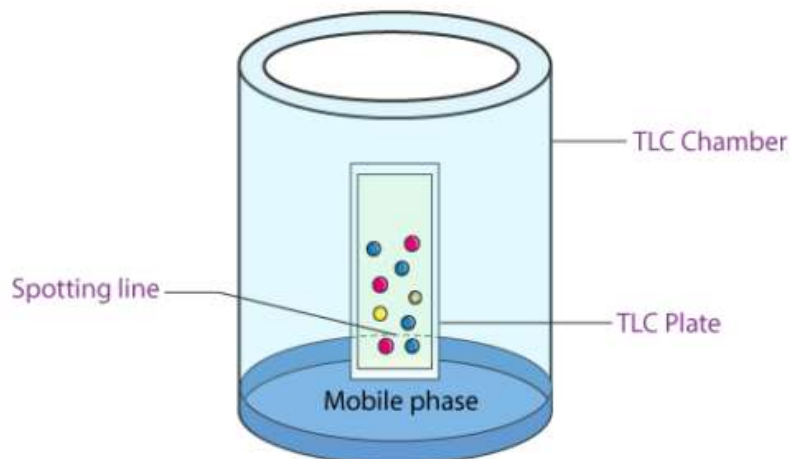

3. Column Chromatography

Column chromatography is the technique used to separate the components of a mixture using a column of suitable adsorbent packed in a glass tube, as shown in the figure below. The mixture is placed on the top of the column, and an appropriate eluant is made to flow down the column slowly.

Depending upon the degree of adsorption of the components on the wall adsorbent column, the separation of the components takes place. The component with the highest adsorptivity is retained at the top, while the other flow down to different heights accordingly.

COLUMN CHROMATOGRAPHY

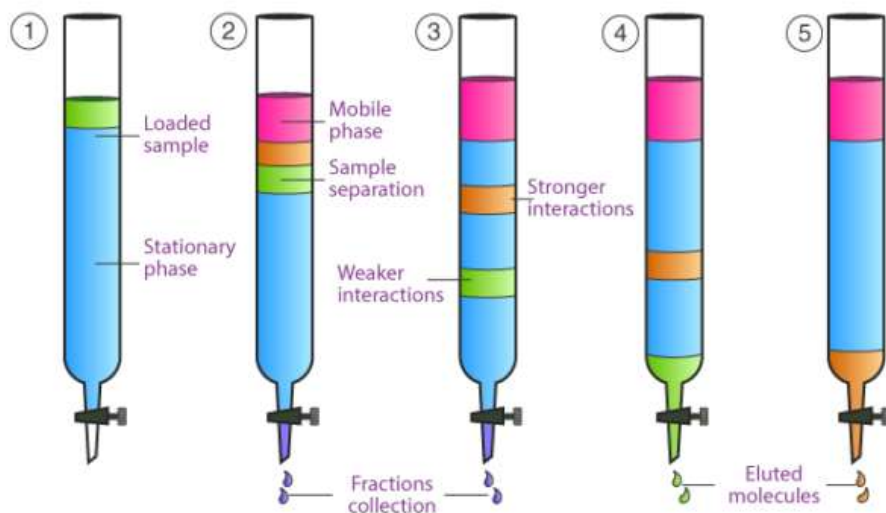

Column Chromatography

4. Partition chromatography

In this process, a continuous differential partitioning of components of a mixture into a stationary phase and mobile phase takes place. The example of partition chromatography can be seen in paper chromatography. In this process, chromatography paper is used as a stationary phase which is suspended in a mixture of solvents that act as a mobile phase.

Here, we put a spot at the base of the chromatographic paper with the mixture to be separated and as the solvent rises up this paper, the components are carried to different degrees depending upon their retention on the paper. The components are thus separated at different heights.

PARTITION CHROMATOGRAPHY

BYJU'S
The Learning App

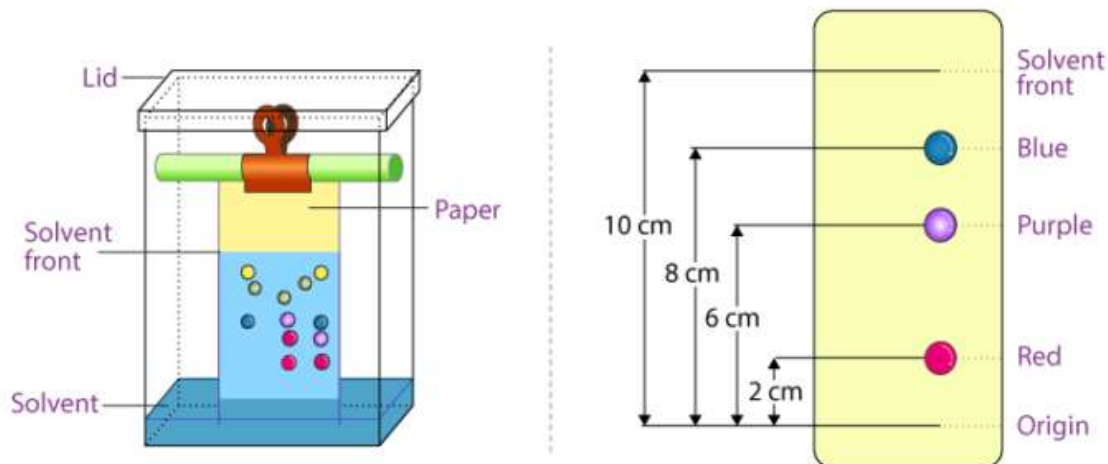

Introduction to Affinity Chromatography

Affinity chromatography is a separation method based on a specific binding interaction between an immobilized ligand and its binding partner. Examples include antibody/antigen, enzyme/substrate, and enzyme/inhibitor interactions. The degree of purification can be quite high depending on the specificity of the interaction and, consequently, it is generally the first step, if not the only step, in a purification strategy.

Principle of Affinity Chromatography

- The stationary phase consists of a support medium, on which the substrate (ligand) is bound covalently, in such a way that the reactive groups that are essential for binding of the target molecule are exposed.
- As the crude mixture of the substances is passed through the chromatography column, substances with binding site for the immobilized substrate bind to the stationary phase, while all other substances is eluted in the void volume of the column.
- Once the other substances are eluted, the bound target molecules can be eluted by methods such as including a competing ligand in the mobile phase or changing the pH, ionic strength or polarity conditions.

Components of Affinity Chromatography

1. Matrix

- The matrix is an inert support to which a ligand can be directly or indirectly coupled.
- In order to for the matrix to be effective it must have certain characters:

- Matrix should be chemically and physically inert.
- It must be insoluble in solvents and buffers employed in the process
- It must be chemically and mechanically stable.
- It must be easily coupled to a ligand or spacer arm onto which the ligand can be attached.
- It must exhibit good flow properties and have a relatively large surface area for attachment.
- The most useful matrix materials are agarose and polyacrylamide.

2. Spacer arm

- It is used to improve binding between ligand and target molecule by overcoming any effects of steric hindrance.

3. Ligand

- It refers to the molecule that binds reversibly to a specific target molecule.
- The ligand can be selected only after the nature of the macromolecule to be isolated is known.
- When a hormone receptor protein is to be purified by affinity chromatography, the hormone itself is an ideal candidate for the ligand.
- For antibody isolation, an antigen or hapten may be used as ligand.
- If an enzyme is to be purified, a substrate analog, inhibitor, cofactor, or effector may be used as the immobilized ligand.

What is Ion Exchange Chromatography?

Ion exchange chromatography (or ion chromatography) is a process that allows the separation of ions and polar molecules based on their affinity to ion exchangers.

The principle of separation is thus by reversible exchange of ions between the target ions present in the sample solution to the ions present on ion exchangers.

In this process, two types of exchangers i.e., cationic and anionic exchangers can be used.

1. **Cationic exchangers** possess negatively charged group, and these will attract positively charged cations. These exchangers are also called “Acidic ion exchange” materials, because their negative charges result from the ionization of acidic group.
 2. **Anionic exchangers** have positively charged groups that will attract negatively charged anions. These are also called “Basic ion exchange” materials.
- Ion exchange chromatography is most often performed in the form of column chromatography. However, there are also thin-layer chromatographic methods that work basically based on the principle of ion exchange.

Working Principle of ion exchange chromatography

This form of chromatography relies on the attraction between oppositely charged stationary phase, known as an ion exchanger, and analyte.

- The ion exchangers basically contain charged groups covalently linked to the surface of an insoluble matrix.
- The charged groups of the matrix can be positively or negatively charged.
- When suspended in an aqueous solution, the charged groups of the matrix will be surrounded by ions of the opposite charge.
- In this “ion cloud”, ions can be reversibly exchanged without changing the nature and the properties of the matrix.

Procedure of ion exchange chromatography

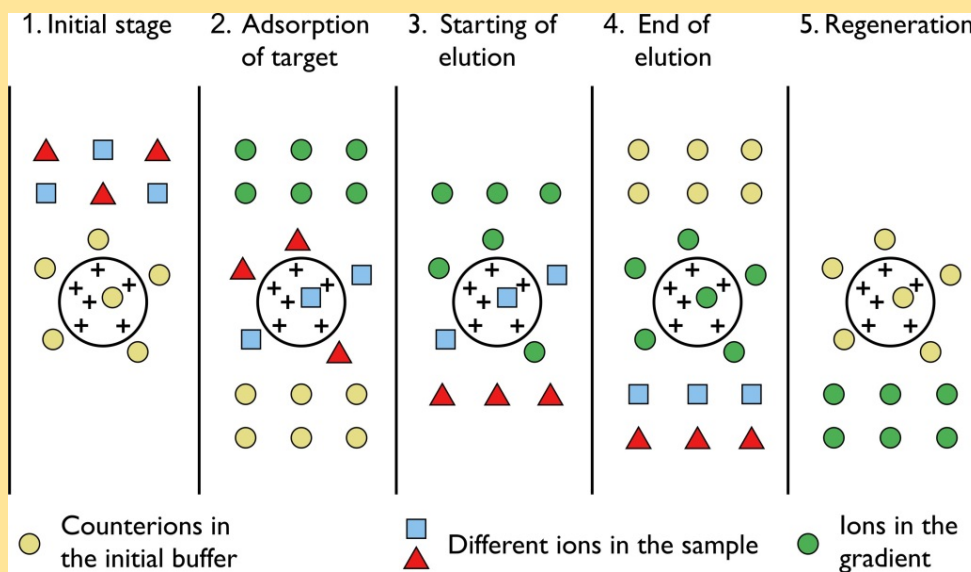

- Ion exchange separations are carried out mainly in columns packed with an ion-exchanger.
- These ionic exchangers are commercially available. They are made up of styrene and divinyl benzene. Example. DEAE-cellulose is an anionic exchanger, CM-cellulose is a cationic exchanger.
- The choice of the exchanger depends upon the charge of particle to be separated. To separate anions “Anionic exchanger” is used, to separate cations “Cationic exchanger” is used.
- First the column is filled with ion exchanger then the sample is applied followed by the buffer. The tris-buffer, pyridine buffer, acetate buffer, citrate and phosphate buffers are widely used.
- The particles which have high affinity for ion exchanger will come down the column along with buffers.
- In next step using corresponding buffer separates the tightly bound particles.
- Then these particles are analyzed spectroscopically.

SDS PAGE

SDS PAGE or Sodium Dodecyl Sulphate-Polyacrylamide Gel Electrophoresis is a technique used for the separation of proteins based on their molecular weight. It is a technique widely used in forensics, genetics, biotechnology and molecular biology to separate the protein molecules based on their electrophoretic mobility.

Principle of SDS-PAGE

The principle of SDS-PAGE states that a charged molecule migrates to the electrode with the opposite sign when placed in an electric field. The separation of the charged molecules depends upon the relative mobility of charged species.

The smaller molecules migrate faster due to less resistance during electrophoresis. The structure and the charge of the proteins also influence the rate of migration. Sodium dodecyl sulphate and polyacrylamide eliminate the influence of structure and charge of the proteins, and the proteins are separated based on the length of the polypeptide chain.

Role of SDS in SDS-PAGE

SDS is a detergent present in the SDS-PAGE sample buffer. SDS along with some reducing agents function to break the disulphide bonds of proteins disrupting the tertiary structure of proteins.

Materials Required

- **Power Supplies:** It is used to convert the AC current to DC current.
- **Gels:** These are either prepared in the laboratory or precast gels are purchased from the market.
- **Electrophoresis Chambers:** The chambers that can fit the SDS-PAGE gels should be used.
- **Protein Samples:** The protein is diluted using SDS-PAGE sample buffer and boiled for 10 minutes. A reducing agent such as dithiothreitol or 2-mercaptoethanol is also added to reduce the disulfide linkages to prevent any tertiary protein folding.
- **Running Buffer:** The protein samples loaded on the gel are run in SDS-PAGE running buffer.
- **Staining and Destaining Buffer:** The gel is stained with Coomassie Stain Solution. The gel is then destained with the destaining solution. Protein bands are then visible under naked eyes.
- **Protein Ladder:** A reference protein ladder is used to determine the location of the protein of interest, based on the molecular size.

Protocol of SDS-PAGE

Preparation of the Gel

- All the reagents are combined, except TEMED, for the preparation of gel.
- When the gel is ready to be poured, add TEMED.
- The separating gel is poured in the casting chamber.
- Add butanol before polymerization to remove the unwanted air bubbles present.
- The comb is inserted in the spaces between the glass plate.
- The polymerized gel is known as the “gel cassette”.

Sample Preparation

- Boil some water in a beaker.

- Add 2-mercaptoethanol to the sample buffer.
- Place the buffer solution in microcentrifuge tubes and add protein sample to it.
- Take MW markers in separate tubes.
- Boil the samples for less than 5 minutes to completely denature the proteins.

Electrophoresis

- The gel cassette is removed from the casting stand and placed in the electrode assembly.
- The electrode assembly is fixed in the clamp stand.
- 1x electrophoresis buffer is poured in the opening of the casting frame to fill the wells of the gel.
- Pipette 30ml of the denatured sample in the well.
- The tank is then covered with a lid and the unit is connected to a power supply.
- The sample is allowed to run at 30mA for about 1 hour.
- The bands are then seen under UV light.

Applications of SDS-PAGE

The applications of SDS-PAGE are as follows:

1. It is used to measure the molecular weight of the molecules.
2. It is used to estimate the size of the protein.
3. Used in peptide mapping
4. It is used to compare the polypeptide composition of different structures.
5. It is used to estimate the purity of the proteins.
6. It is used in Western Blotting and protein ubiquitination.
7. It is used in HIV test to separate the HIV proteins.
8. Analyzing the size and number of polypeptide subunits.
9. To analyze post-translational modifications.

What is gas chromatography mass spectrometry?

Gas chromatography mass spectrometry (GC-MS) consists of two very different analytical techniques: gas chromatography (GC) which is hyphenated (hence uses a hyphen not a forward slash) to mass spectrometry (MS). Usually, the analytical instrument consists of a gas chromatograph that is hyphenated via a heated transfer line to the mass spectrometer, and the two techniques take place in series.

GC is a separation science technique that is used to separate the chemical components of a sample mixture and then detect them to determine their presence or absence and/or how much is present. GC detectors are limited in the information that they give; this is usually two-dimensional giving the retention time on the analytical column and the detector response. Identification is based on comparison of the retention time of the peaks in a sample to those from standards of known compounds, analyzed using the same method. However, GC alone cannot be used for the identification of unknowns, which is where hyphenation to an MS works very well. MS can be used as a sole detector, or the column effluent can be split between the MS and GC detector(s).

MS is an analytical technique that measures the mass-to-charge ratio (m/z) of charged particles and therefore can be used to determine the molecular weight and elemental composition, as well as elucidating the chemical structures of molecules. Data from a GC-MS is three-dimensional, providing mass spectra that can be used for identity confirmation or to identify unknown compounds plus the chromatogram that can be used for qualitative and quantitative analysis.

How does a GC-MS instrument work?

The sample mixture is first separated by the GC before the analyte molecules are eluted into the MS for detection.¹ They are transported by the carrier gas (Figure 1 (1)), which continuously flows through the GC and into the MS, where it is evacuated by the vacuum system (6).

1. The sample is first **introduced** into the GC manually or by an autosampler (Figure 1 (2)) and enters the carrier gas via the GC inlet (Figure 1 (3)). If the sample is in the liquid form, it is vaporized in the heated GC inlet and the sample vapor is transferred to the analytical column (Figure 1 (4)).

2. The sample components, the “analytes”, are **separated** by their differences in partitioning between the mobile phase (carrier gas) and the liquid stationary phase (held within the column), or for more volatile gases their adsorption by a solid stationary phase. In GC-MS analyses, a liquid stationary phase held within a narrow (0.1-0.25 mm internal diameter) and short (10-30 m length) column is most common.

3. After separation, which for GC-MS analyses doesn't require total baseline resolution unless the analytes are isomers, the neutral molecules **elute** through a heated transfer line (Figure 1 (5)) into the mass spectrometer.

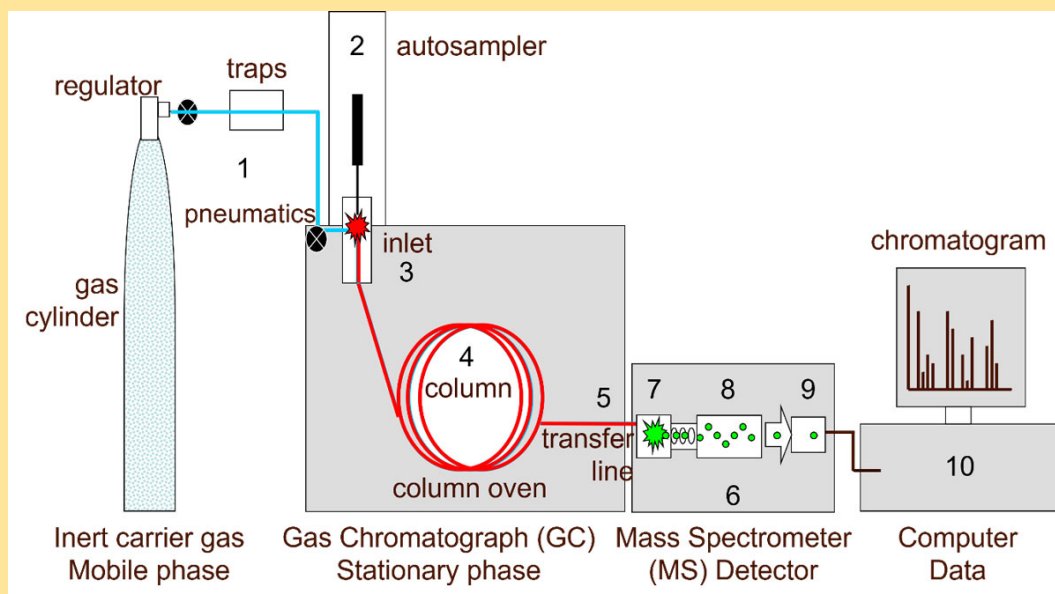

- Analysis & Separations
- Articles
- Content Piece

GC-MS Principle, Instrument and Analyses and GC-MS/MS

Article

What is gas chromatography mass spectrometry?

Gas chromatography mass spectrometry (GC-MS) consists of two very different analytical techniques: gas chromatography (GC) which is hyphenated (hence uses a hyphen not a forward slash) to mass spectrometry (MS). Usually, the analytical instrument consists of a gas chromatograph that is hyphenated via a heated transfer line to the mass spectrometer, and the two techniques take place in series. However, some specialist and usually miniature or portable instruments contain the whole GC-MS within a single box

GC is a separation science technique that is used to separate the chemical components of a sample mixture and then detect them to determine their presence or absence and/or how much is present. GC detectors are limited in the information that they give; this is usually two-dimensional giving the retention time on the analytical column and the detector response. Identification is based on comparison of the retention time of the peaks in a sample to those from standards of known compounds, analyzed using the same method. However, GC alone cannot be used for the identification of unknowns, which is where hyphenation to an MS works very well. MS can be used as a sole detector, or the column effluent can be split between the MS and GC detector(s).

MS is an analytical technique that measures the mass-to-charge ratio (m/z) of charged particles and therefore can be used to determine the molecular weight and elemental composition, as well as elucidating the chemical structures of molecules. Data from a GC-MS is three-dimensional, providing mass spectra that can be used for identity confirmation or to identify unknown compounds plus the chromatogram that can be used for qualitative and quantitative analysis.

How does a GC-MS instrument work?

The sample mixture is first separated by the GC before the analyte molecules are eluted into the MS for detection.¹ They are transported by the carrier gas (Figure 1 (1)), which continuously flows through the GC and into the MS, where it is evacuated by the vacuum system (6).

1. The sample is first **introduced** into the GC manually or by an autosampler (Figure 1 (2)) and enters the carrier gas via the GC inlet (Figure 1 (3)). If the sample is in the liquid form, it is vaporized in the heated GC inlet and the sample vapor is transferred to the analytical column (Figure 1 (4)).

2. The sample components, the “analytes”, are **separated** by their differences in partitioning between the mobile phase (carrier gas) and the liquid stationary phase (held within the column), or for more volatile gases their adsorption by a solid stationary phase. In GC-MS analyses, a liquid stationary phase held within a narrow (0.1-0.25 mm internal diameter) and short (10-30 m length) column is most common.

3. After separation, which for GC-MS analyses doesn't require total baseline resolution unless the analytes are isomers, the neutral molecules **elute** through a heated transfer line (Figure 1 (5)) into the mass spectrometer.

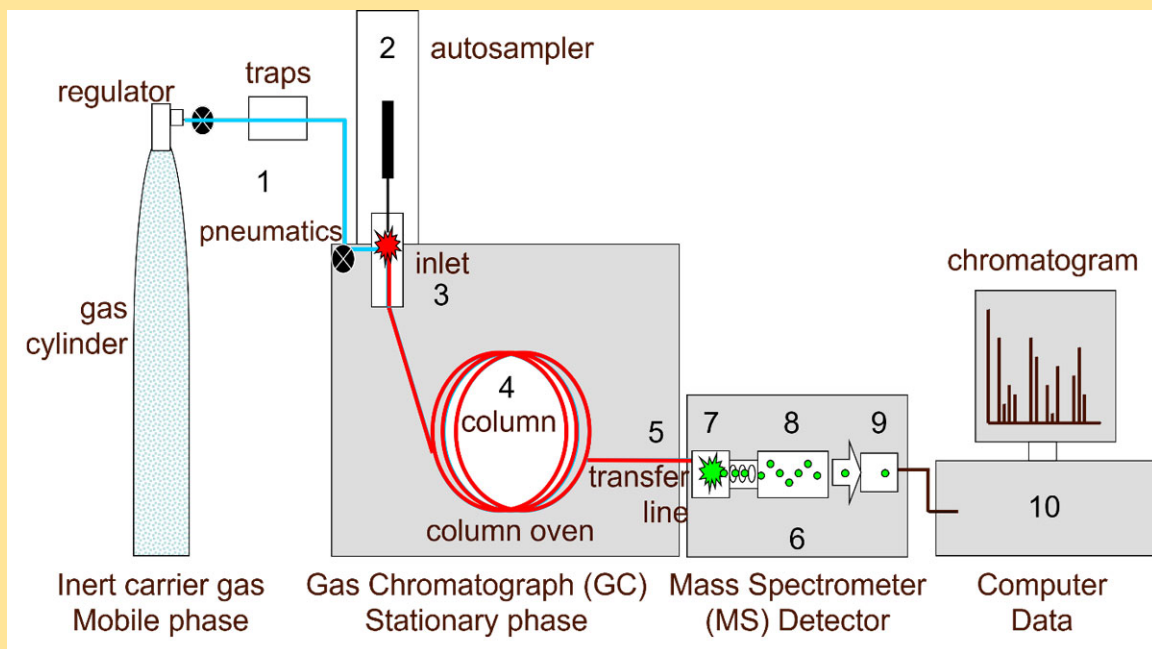

4. Within the mass spectrometer, the neutral molecules are first **ionized**, most commonly by **electron ionization (EI)**. In EI, an electron, produced by a filament, is accelerated with 70 electron volts (eV) and knocks an electron out of the molecule to produce a molecular ion that is a radical cation. This high energy ionization can result in an unstable molecular ion and excess energy can be lost through fragmentation. Bond breakage(s) can lead to the loss of a radical or neutral molecule and molecular rearrangements can also occur. This all results in a, sometimes very large, number of ions of different masses, the heaviest being the molecular ion with fragment ions of various lower masses, depending on:

- the molecular formula
- the molecular structure of the analyte
- where bond breakage has occurred
- which part has retained the charge

5. The next step is to **separate** the ions of different masses, which is achieved based on their m/z by the mass analyzer (Figure 1 (8)).

6. After the ions have been separated by the mass analyzer based on their m/z , they reach the **ion detector** (Figure 1 (9)) where the signal is amplified by an **electron multiplier** (for most low resolution MS) or a **multi-channel plate** (for most HRMS instruments). The signal is recorded by the acquisition software on a computer (Figure 1 (10)) to produce a chromatogram and a mass spectrum for each data point.

HPLC:

What is High-performance liquid chromatography (HPLC)?

High-performance liquid chromatography or commonly known as HPLC, is an analytical technique used to separate, identify or quantify each component in a mixture.

The mixture is separated using the basic principle of column **chromatography** and then identified and quantified by spectroscopy.

In the 1960s, the column chromatography LC with its low-pressure suitable glass columns was further developed to the HPLC with its high-pressure adapted metal columns.

HPLC is thus basically a highly improved form of column liquid chromatography. Instead of a solvent being allowed to drip through a column under gravity, it is forced through under high pressures of up to 400 atmospheres.

Principle of High-Performance Liquid Chromatography (HPLC)

- The purification takes place in a separation column between a stationary and a mobile phase.
- The stationary phase is a granular material with very small porous particles in a separation column.
- The mobile phase, on the other hand, is a solvent or solvent mixture which is forced at high pressure through the separation column.
- Via a valve with a connected sample loop, i.e. a small tube or a capillary made of stainless steel, the sample is injected into the mobile phase flow from the pump to the separation column using a syringe.
- Subsequently, the individual components of the sample migrate through the column at different rates because they are retained to a varying degree by interactions with the stationary phase.
- After leaving the column, the individual substances are detected by a suitable detector and passed on as a signal to the HPLC software on the computer.
- At the end of this operation/run, a chromatogram in the HPLC software on the computer is obtained.
- The chromatogram allows the identification and quantification of the different substances.

Instrumentation of High-Performance Liquid Chromatography (HPLC)

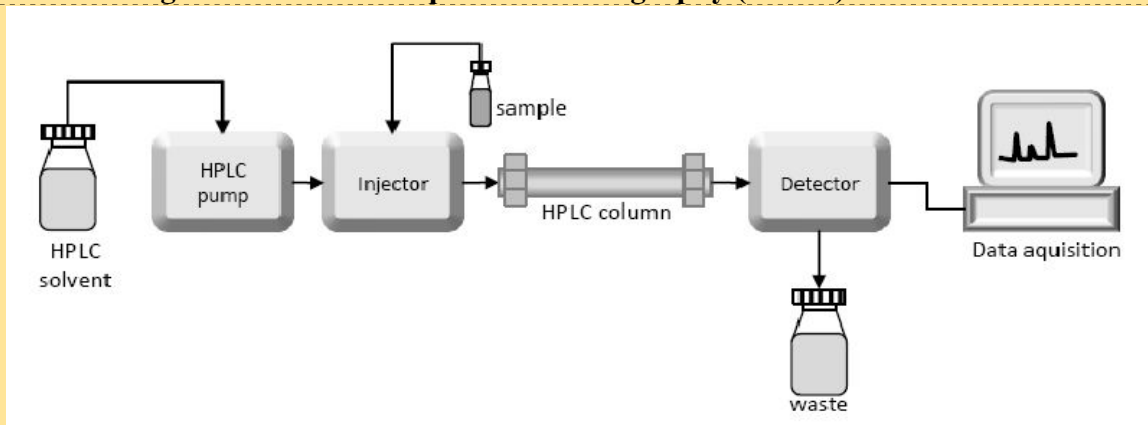

The Pump

- The development of HPLC led to the development of the pump system.
- The pump is positioned in the most upper stream of the liquid chromatography system and generates a flow of eluent from the solvent reservoir into the system.
- High-pressure generation is a “standard” requirement of pumps besides which, it should also be able to provide a consistent pressure at any condition and a controllable and reproducible flow rate.
- Most pumps used in current LC systems generate the flow by back-and-forth motion of a motor-driven piston (reciprocating pumps). Because of this piston motion, it produces “pulses”.

Injector

- An injector is placed next to the pump.
- The simplest method is to use a syringe, and the sample is introduced to the flow of eluent.
- The most widely used injection method is based on sampling loops.
- The use of the autosampler (auto-injector) system is also widely used that allows repeated injections in a set scheduled-timing.

Column

- The separation is performed inside the column.
- The recent columns are often prepared in a stainless steel housing, instead of glass columns.
- The packing material generally used is silica or polymer gels compared to calcium carbonate. The eluent used for LC varies from acidic to basic solvents.
- Most column housing is made of stainless steel since stainless is tolerant towards a large variety of solvents.

Detector

- Separation of analytes is performed inside the column, whereas a detector is used to observe the obtained separation.
- The composition of the eluent is consistent when no analyte is present. While the presence of analyte changes the composition of the eluent. What detector does is to measure these differences.
- This difference is monitored as a form of an electronic signal. There are different types of detectors available.

Recorder

- The change in eluent detected by a detector is in the form of an electronic signal, and thus it is still not visible to our eyes.
- In older days, the pen (paper)-chart recorder was popularly used. Nowadays, a computer-based data processor (integrator) is more common.
- There are various types of data processors; from a simple system consisting of the in-built printer and word processor while those with software that are specifically designed for an LC system which not only data acquisition but features like peak-fitting, baseline correction, automatic concentration calculation, molecular weight determination, etc.

Degasser

- The eluent used for LC analysis may contain gases such as oxygen that are non-visible to our eyes.
- When gas is present in the eluent, this is detected as noise and causes an unstable baseline.
- Degasser uses special polymer membrane tubing to remove gases.
- The numerous very small pores on the surface of the polymer tube allow the air to go through while preventing any liquid to go through the pore.

Column Heater

- The LC separation is often largely influenced by the column temperature.
- In order to obtain repeatable results, it is important to keep consistent temperature conditions.
- Also for some analysis, such as sugar and organic acid, better resolutions can be obtained at elevated temperatures (50 to 80°C).
- Thus columns are generally kept inside the column oven (column heater).

Types of High-Performance Liquid Chromatography (HPLC)

1. Normal phase:

Column packing is polar (e.g silica) and the mobile phase is non-polar. It is used for water-sensitive compounds, geometric isomers, cis-trans isomers, and chiral compounds.

2. Reverse phase:

The column packing is non-polar (e.g C18), the mobile phase is water+ miscible solvent (e.g methanol). It can be used for polar, non-polar, ionizable, and ionic samples.

3. Ion exchange:

Column packing contains ionic groups and the mobile phase is buffer. It is used to separate anions and cations.

4. Size exclusion:

Molecules diffuse into pores of a porous medium and are separated according to their relative size to the pore size. Large molecules elute first and smaller molecules elute later.

What is Blotting technique?

In molecular biology and genetics, blotting is an analysis technique used for the detection of specific biomolecules (proteins, DNA or RNA) in samples of complex composition by transferring them onto a carrier such as a nitrocellulose, polyvinylidene fluoride or nylon membrane.

- In most cases, the Blotting technique is performed after gel electrophoresis by transferring the molecules from the gel to the blotting membrane or often they are transferred directly onto the membrane.
- After transferring, the proteins, DNA or RNA molecules are visualized by using colorant staining such as silver staining of proteins or by autoradiographic visualization of radiolabelled molecules (performed before the blot), or specific labeling of some proteins or nucleic acids.
- After that, antibodies or hybridization probes are binds only to specific molecules of the blot and have an enzyme joined to them.
- After washing the blot, it incubation with a proper reactive as result it will visualize the enzymatic activity (and so, the molecules we search in the blot). Performing either a colored film on the blot or a chemiluminescent reaction which is recorded by photographic film.
- This method is an adjunct to gel electrophoresis which involves the separation of DNA, RNA and proteins with exceptional resolving power.
- The blotting technique mainly applied to those biomolecules which are stably adhered to nitrocellulose, nylon or paper membrane and are still capable to bind their cognate ligand.
- Before performing the transfer of biomolecules, they are must be separated according to their size range.
- There are different types of blotting techniques, among them, three are important such as, Southern blotting, western blotting, and Northern blotting.
- The blotting method was first discovered by Edwin M. Southern in 1975 for DNA. In his method, the DNA restriction fragments which are electrophoretically fractionated in an agarose gel are transferred to a solid support (nitrocellulose) and recognized as discrete bands following hybridization to a complementary DNA probe.
- When the Southern blotting method was applied to RNA, it was known as Northern Blotting.

- In Western blotting, the proteins are transferred to a membrane and their detection was done by antibody probe.
- All these blotting methods follow the common steps, which involve the transfers of molecules from the gel to a porous membrane, most often performed by soaking solution through the gel and the membrane applying absorptive paper.
- In blotting the detection of a specific sequence on DNA and RNA in the membrane is done by performing molecular hybridization with labeled nucleic acid probes.
- The proteins are mainly detected by using labeled antibodies.

Southern blotting

This method was named after Edward M. Southern and only used for the **analysis of DNA** sequences. The southern blotting is completed in these following steps;

1. First of all the Large DNA is fragmented into small pieces by using Restriction endonucleases.
2. This fragmented DNA are separated according to their size by using gel electrophoresis.
3. The Larger DNA fragments are treated with HCl, which causes depurination of DNA fragments.
4. After electrophoresis, the separated fragments are transferred onto a nitrocellulose sheet. The pressure is applied over the membrane to confirm the proper interaction occur between these two gel and membrane.
5. The membrane is exposed to ultraviolet radiation as result the fragments will permanently attached to the membrane.
6. Then the membrane is exposed to a hybridization probe. But the DNA probe is labeled so that it can easily detect when the molecule is tagged with a chromogenic dye.
7. The membrane is washed using an SSC buffer to remove the excess probe.
8. Finally the membrane is visualized on X-ray film with the help of autoradiography.

Southern blotting Applications

- Used in RFLP (Restriction fragment length polymorphism) mapping.
- Southern blotting used in phylogenetic analysis.
- It is used to detect gene rearrangements.

Northern blotting

Principle

The fundamental principle of northern blotting is to separate RNA based on their size using gel electrophoresis and identified on a cellular membrane by means of hybridization probe with a base sequence corresponding to all or a part of the chain of the target RNA. Initially, we extract RNA from a tissue through chaotropic agents such as guanidinium isothiocyanate to cause disrupting in cells and denaturing the proteins as well as dissolving the RNA. Some cases require the isolation of mRNA from total RNA using a poly-A⁺ selection procedure. The derived RNA then undergoes agarose-gel electrophoresis where it gets separated which is then proceeded by blotting onto a nylon membrane. The RNA on the membrane must be immobilized after blotting through baking or exposure under UV light avoiding nucleic acid to wash away later. Finally, hybridization probe is made ready and the probe is hybridized with the membrane. A post hybridization wash is required so that the probe is bounded to

target mRNA or not is ensured. The signals are then detected and visualized using x-films and other methods.

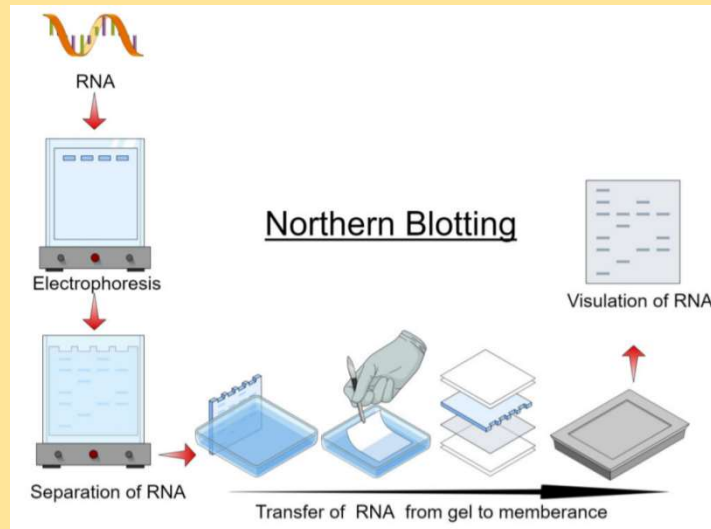

Northern blotting

Procedure

1. RNA Isolation

- Multiple ways of isolating RNA but all have some common attributes such as cellular lysis and membrane disruption, inhibiting of ribonuclease activity, deprotenization and recovery of intact RNA.
- Some of the common methods of RNA extraction are:

RNA isolation by acid guanidinium thiocyanate phenol chloroform extraction.

RNA isolation by column based technology.

- Assessment of quantity and quality of RNA through spectrophotometry.

2. Separation of RNA using gel Electrophoresis

- RNA have secondary structure formed by intramolecular base pairing that prevents RNA from separation according to their size.
- Denaturing agent (formaldehyde or glyoxal/DMSO) disrupts the secondary structure.
- Separation of RNA is better in glyoxal/DMSO system as sharper band for specific RNA is detected by hybridization.
- Size of RNA fragments are compared by migration distance with those of molecular weight markers.
- Gels are stained with ethidium bromide after electrophoresis to detect molecular markers and rRNAs.

3. Transfer of RNA to a membrane

- Nitrocellulose and nylons are commonly used membranes. (Nylon membrane are more durable)
- RNA are transferred via capillary or vacuum transfer. Vacuum transfer are more efficient but require special transfer apparatus.

- Electrophoretic transfer method is available only for nylon membrane due to low concentration of salts required to bind the RNA.
- Transferred RNA are then immobilized to membrane by baking at 80 °C or through UV crosslinking in case of nylon membrane.

4. Hybridization and Washing

- Hybridization is performed using radio or fluorescently labelled probe to identify specific RNA immobilization.
- Pre-hybridization blocks single stranded probe from binding on non-specific sites on the membrane.
- Hybridization solution should contain 50% formamide to ensure hybridization at lower temperature and minimize RNA degradation.
- The membrane is washed in the buffer containing lower concentration of salt to remove excess probes.

5. Visualization

- Detection of specific transcript through autoradiography.
- Membranes are place over X-ray film.
- The X-ray film darkens where fragments are corresponding to the radioactive probes.

Western blotting:

Introduction

Western blot is the analytical technique used in molecular biology, immunogenetics, and other molecular biology to detect specific proteins in a sample of tissue homogenate or extract. Western blotting is called so as the procedure is similar to Southern blotting. While Southern blotting is done to detect DNA, Western blotting is done for the detection of proteins. Western blotting is also called protein immunoblotting because an antibody is used to specifically detect its antigen.

Principle of Western blotting

The technique consists of three major processes:

1. Separation of proteins by size (Electrophoresis).
2. Transfer to a solid support (Blotting)
3. Marking target protein using a proper primary and secondary antibody to visualize (Detection).

Electrophoresis used to separate proteins according to their electrophoretic mobility which depends on the charge, size of protein molecule, and structure of the proteins. Proteins are moved from within the gel onto a membrane made of Nitrocellulose (NC) or Polyvinylidene difluoride (PVDF). Without pre-activation, proteins combine with nitrocellulose membrane based on hydrophobic interaction (**Blotting**). For detection of the proteins, primary antibody and enzyme-conjugated secondary antibody are used. In addition of substrate, a substrate reacts with the enzyme that is bound to the secondary antibody to generate colored substance, namely, visible protein bands.

In this technique, a mixture of proteins is separated based on molecular weight, and thus by type, through gel electrophoresis. These results are then transferred to a membrane producing a band for each protein. The membrane is then incubated with labels antibodies specific to the protein of interest. The unbound antibody is washed off leaving only the bound antibody to the protein of interest. The bound antibodies are then detected by developing the film. As the antibodies only bind to the protein of

interest, only one band should be visible. The thickness of the band corresponds to the amount of protein present; thus doing a standard can indicate the amount of protein present.

Western blotting is usually done on a tissue homogenate or extract. It utilizes **SDS-PAGE (Sodium dodecyl sulfate polyacrylamide gel electrophoresis)**, a type of gel electrophoresis to first separate various proteins in a mixture on the basis of their shape and size. The protein bands thus obtained are transferred onto a **nitrocellulose or nylon membrane** where they are “probed” with antibodies specific to the protein to be detected. The antigen-antibody complexes that form on the band containing the protein recognized by the antibody can be visualized in a variety of ways.

If the protein of interest is bound by a radioactive antibody, its position on the blot can be determined by exposing the membrane to a sheet of X-ray film, a procedure called **autoradiography**. However, the most generally used detection procedures employ enzyme-linked antibodies against the protein. After binding of the enzyme–antibody conjugate, the addition of a chromogenic substrate that produces a highly colored and insoluble product causes the appearance of a colored band at the site of the target antigen. The site of the protein of interest can be determined with a much higher sensitivity if a chemiluminescent compound along with suitable enhancing agents is used to produce light at the antigen site.

Applications

- Standard for studying and inspecting gene manifestation design between tissues, organs, developmental stages, pathogen infection, and over the course of treatment.
- Diagnosis of several diseases (Crohn’s diseases) including viral infection.
- Exhibit overexpression of oncogenes and down regulation of tumor suppressor genes in cancerous cells.
- Study of RNA degradation and splicing.
- Detect specific mRNA molecular weights and contents in a sample.
- Identify mRNA produced by the transgene to protect recombinants

Agarose Gel Electrophoresis

- Agarose gel electrophoresis is a method of gel electrophoresis used in biochemistry, molecular biology, genetics, and clinical chemistry to separate a mixed population of macromolecules such as DNA , RNA or proteins in a matrix of agarose.
- Agarose is a natural linear polymer extracted from seaweed that forms a gel matrix by hydrogen-bonding when heated in a buffer and allowed to cool.
- They are the most popular medium for the separation of moderate and large-sized nucleic acids and have a wide range of separation.

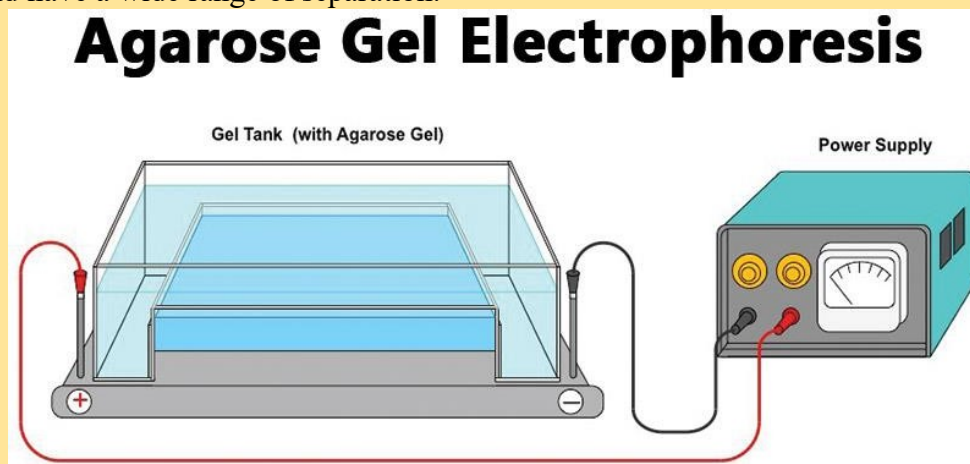

Principle of Agarose Gel Electrophoresis

Gel electrophoresis separates DNA fragments by size in a solid support medium such as an agarose gel. Sample (DNA) are pipetted into the sample wells, followed by the application of an electric current at the anodal, negative end which causes the negatively-charged DNA to migrate (electrophorese) towards the bottom (cathodal, positive) end. The rate of migration is proportional to size: smaller fragments move more quickly, and wind up at the bottom of the gel.

DNA is visualized by including in the gel an intercalating dye, ethidium bromide. DNA fragments take up the dye as they migrate through the gel. Illumination with ultraviolet light causes the intercalated dye to fluoresce.

The larger fragments fluoresce more intensely. Although each of the fragments of a single class of molecule are present in equimolar proportions, the smaller fragments include less mass of DNA, take up less dye, and therefore fluoresce less intensely. A "ladder" set of DNA fragments of known size can be run simultaneously and used to estimate the sizes of the other unknown fragments.

Requirements/ Instrumentation of Agarose Gel Electrophoresis

The equipment and supplies necessary for conducting agarose gel electrophoresis are relatively simple and include:

1. An **electrophoresis chamber** and **power supply**
2. **Gel casting trays**, which are available in a variety of sizes and composed of UVtransparent plastic. The open ends of the trays are closed with tape while the gel is being cast, then removed prior to electrophoresis.
3. **Sample combs**, around which molten medium is poured to form sample wells in the gel.
4. **Electrophoresis buffer**, usually Tris-acetate-EDTA (TAE) or Tris-borate-EDTA (TBE).
5. **Loading buffer**, which contains something dense (e.g. glycerol) to allow the sample to “fall” into the sample wells, and one or two tracking dyes, which migrate in the gel and allow visual monitoring or how far the electrophoresis has proceeded.
6. **Staining**: DNA molecules are easily visualized under an ultraviolet lamp when electrophoresed in the presence of the extrinsic fluor ethidium bromide. Alternatively, nucleic acids can be stained after electrophoretic separation by soaking the gel in a solution of ethidium bromide. When intercalated into doublestranded DNA, fluorescence of this molecule increases greatly. It is also possible to detect DNA with the extrinsic fluor 1- anilino 8-naphthalene sulphonate.
7. **Transilluminator** (an ultraviolet light box), which is used to visualize stained DNA in gel

Steps Involved in Agarose Gel Electrophoresis

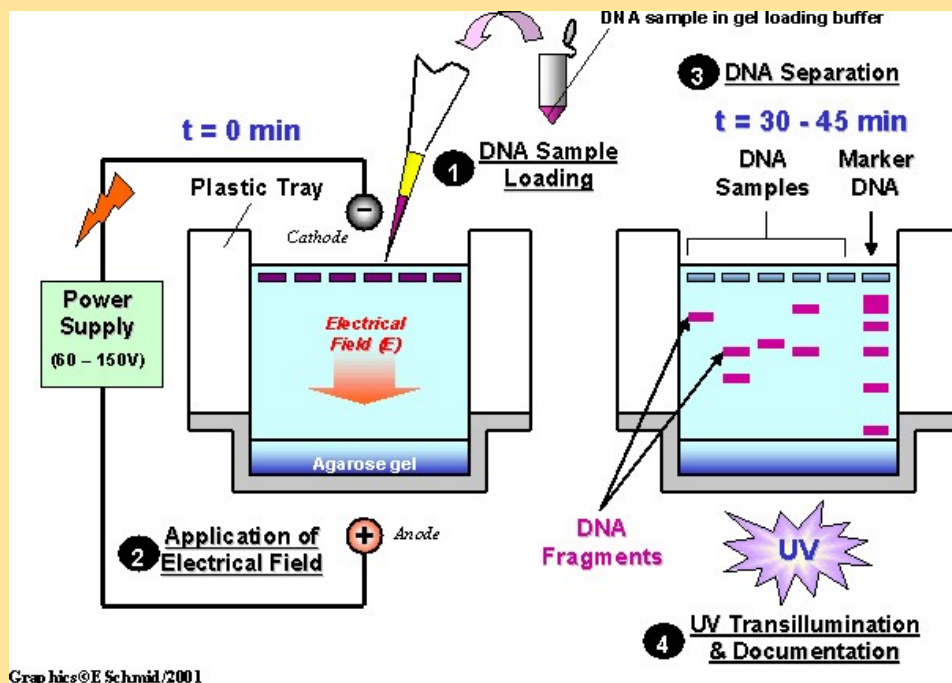

1. To prepare gel, agarose powder is mixed with electrophoresis buffer to the desired concentration, and heated in a microwave oven to melt it.

The concentration of Agarose Gel

- The percentage of agarose used depends on the size of fragments to be resolved.
 - The concentration of agarose is referred to as a percentage of agarose to volume of buffer (w/v), and agarose gels are normally in the range of 0.2% to 3%.
 - The lower the concentration of agarose, the faster the DNA fragments migrate.
 - In general, if the aim is to separate large DNA fragments, a low concentration of agarose should be used, and if the aim is to separate small DNA fragments, a high concentration of agarose is recommended.
2. Ethidium bromide is added to the gel (final concentration 0.5 ug/ml) to facilitate visualization of DNA after electrophoresis.
 3. After cooling the solution to about 60°C, it is poured into a casting tray containing a sample comb and allowed to solidify at room temperature.
 4. After the gel has solidified, the comb is removed, taking care not to rip the bottom of the wells.

 5. The gel, still in plastic tray, is inserted horizontally into the electrophoresis chamber and is covered with buffer.
 6. Samples containing DNA mixed with loading buffer are then pipetted into the sample wells, the lid and power leads are placed on the apparatus, and a current is applied.
 7. The current flow can be confirmed by observing bubbles coming off the electrodes.
 8. DNA will migrate towards the positive electrode, which is usually colored red, in view of its negative charge.
 9. The distance DNA has migrated in the gel can be judged by visually monitoring migration

of the tracking dyes like bromophenol blue and xylene cyanol dyes

Applications of Agarose Gel Electrophoresis

Agarose gel electrophoresis is a routinely used method for separating proteins, DNA or RNA.

- Estimation of the size of DNA molecules
 - Analysis of PCR products, e.g. in molecular genetic diagnosis or genetic fingerprinting
 - Separation of restricted genomic DNA prior to Southern analysis, or of RNA prior to Northern analysis.
 - The agarose gel electrophoresis is widely employed to estimate the size of DNA fragments after digesting with restriction enzymes, e.g. in restriction mapping of cloned DNA.
 - Agarose gel electrophoresis is commonly used to resolve circular DNA with different supercoiling topology, and to resolve fragments that differ due to DNA synthesis.
 - In addition to providing an excellent medium for fragment size analyses, agarose gels allow purification of DNA fragments. Since purification of DNA fragments size separated in an agarose gel is necessary for a number molecular techniques such as cloning, it is vital to be able to purify fragments of interest from the gel.
-

Advantages of Agarose Gel Electrophoresis

- For most applications, only a single-component agarose is needed and no polymerization catalysts are required. Therefore, agarose gels are simple and rapid to prepare.
 - The gel is easily poured, does not denature the samples.
 - The samples can also be recovered.
-

Disadvantages of Agarose Gel Electrophoresis

- Gels can melt during electrophoresis.
- The buffer can become exhausted.
- Different forms of genetic material may run in unpredictable forms.

SDS - Polyacrylamide Gel Electrophoresis (SDS - PAGE)-Separation of Protein

- Electrophoresis through **agarose** or polyacrylamide gels is a standard method used to separate, identify and purify biopolymers, since both these gels are porous in nature.
- Polyacrylamide gels are chemically cross-linked gels formed by the polymerization of acrylamide with a cross-linking agent, usually N,N'-methylenebisacrylamide.
- The reaction is a free radical polymerization, usually carried out with ammonium persulfate as the initiator and N,N,N',N'-tetramethylethylenediamine (TEMED) as the catalyst.
- Polyacrylamide gel electrophoresis (PAGE) is a technique widely used in biochemistry, forensic chemistry, genetics, molecular biology and biotechnology to separate biological macromolecules, usually proteins or nucleic acids, according to their electrophoretic mobility.
- The most commonly used form of polyacrylamide gel electrophoresis is the Sodium dodecyl sulphate Polyacrylamide gel electrophoresis (SDS- PAGE) used mostly for the **separation of proteins**.

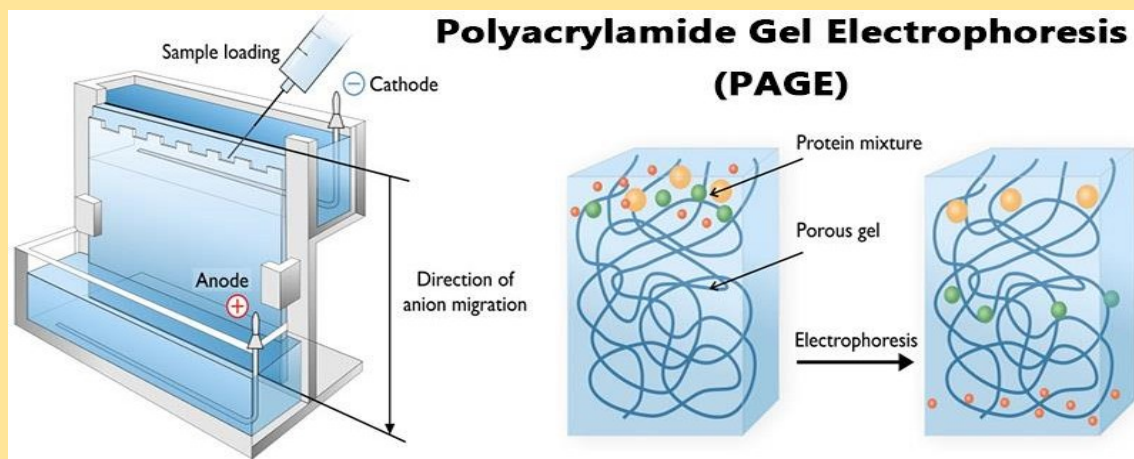

Principle of SDS -Polyacrylamide Gel Electrophoresis (SDS-PAGE)

SDS-PAGE (Polyacrylamide Gel Electrophoresis), is an analytical method used to separate components of a protein mixture based on their size.

The technique is based upon the principle that a charged molecule will migrate in an electric field towards an electrode with opposite sign. The general electrophoresis techniques cannot be used to determine the molecular weight of biological molecules because the mobility of a substance in the gel depends on both charge and size.

To overcome this, the biological samples need to be treated so that they acquire uniform charge, then the electrophoretic mobility depends primarily on size. For this different protein molecules with different shapes and sizes, need to be denatured (done with the aid of SDS) so that the proteins lose their secondary, tertiary or quaternary structure. The proteins being covered by SDS are negatively charged and when loaded onto a gel and placed in an electric field, it will migrate towards the anode (positively charged electrode) and are separated by a molecular

sieving effect based on size. After the visualization by a staining (protein-specific) technique, the size of a protein can be calculated by comparing its migration distance with that of a known molecularweight ladder (marker).

Requirements for Polyacrylamide Gel Electrophoresis (SDS-PAGE)

- Acrylamide solutions (for resolving & stacking gels).
- Isopropanol / distilled water.
- Gel loading buffer.
- Running buffer.
- Staining, destaining solutions.
- Protein samples
- Molecular weight markers.

The equipment and supplies necessary for conducting SDS-PAGE includes:

- An electrophoresis chamber and power supply.
- Glass plates (a short and a top plate).
- Casting frame
- Casting stand
- Combs

Steps Involved in Polyacrylamide Gel Electrophoresis (SDS-PAGE)

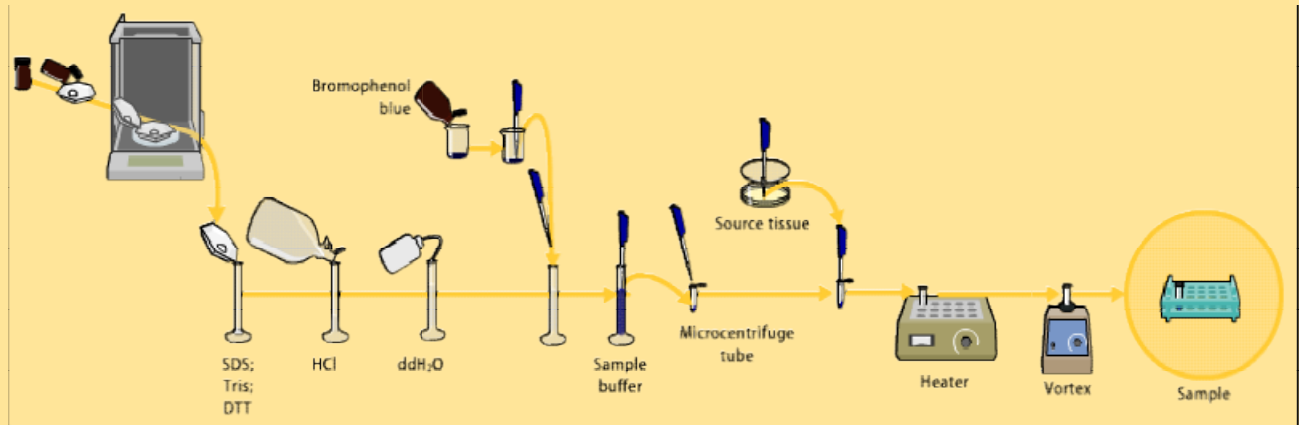

1. Sample preparation

- Samples may be any material containing proteins or nucleic acids.
- The sample to analyze is optionally mixed with a chemical denaturant if so desired, usually SDS for proteins or urea for nucleic acids.
- SDS is an anionic detergent that denatures secondary and non-disulfide-linked tertiary structures, and additionally applies a negative charge to each protein in proportion to its mass. Urea breaks the hydrogen bonds between the base pairs of the nucleic acid, causing the constituent strands to anneal. Heating the samples to at least 60 °C further promotes denaturation.
- A tracking dye may be added to the solution. This typically has a higher electrophoretic mobility than the analytes to allow the experimenter to track the progress of the solution through the gel during the electrophoretic run.

2. Preparation of polyacrylamide gel

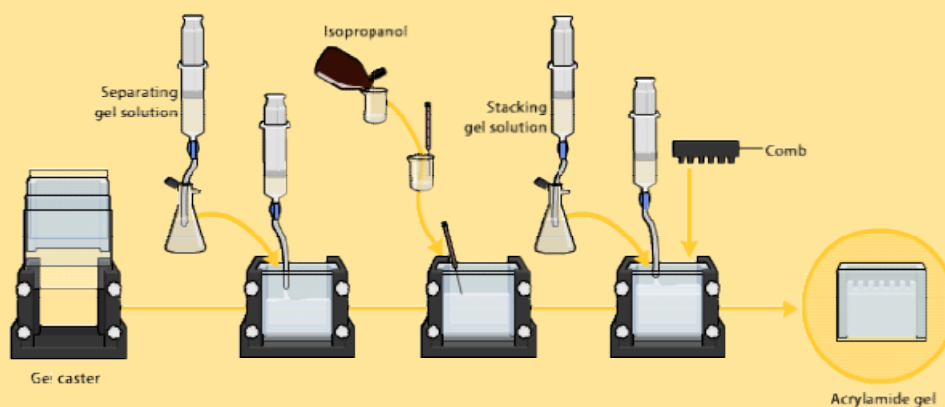

- The gels typically consist of acrylamide, bisacrylamide, the optional denaturant (SDS or urea), and a buffer with an adjusted pH.
- The ratio of bisacrylamide to acrylamide can be varied for special purposes, but is generally about 1 part in 35. The acrylamide concentration of the gel can also be varied, generally in the range from 5% to 25%.
- Lower percentage gels are better for resolving very high molecular weight molecules, while much higher percentages of acrylamide are needed to resolve smaller proteins,
- Gels are usually polymerized between two glass plates in a gel caster, with a comb inserted at the top to create the sample wells.
- After the gel is polymerized the comb can be removed and the gel is ready for electrophoresis.

3. Electrophoresis

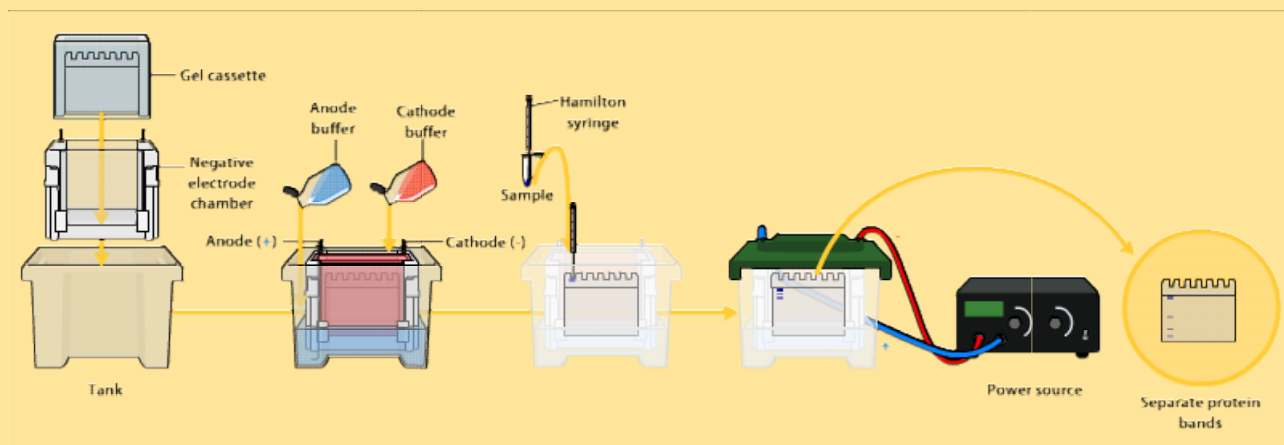

- Various buffer systems are used in PAGE depending on the nature of the sample and the experimental objective.
- The buffers used at the anode and cathode may be the same or different.
- An electric field is applied across the gel, causing the negatively charged proteins or nucleic acids to migrate across the gel away from the negative and towards the positive electrode (the anode).

- Depending on their size, each biomolecule moves differently through the gel matrix: small molecules more easily fit through the pores in the gel, while larger ones have more difficulty.
- The gel is run usually for a few hours, though this depends on the voltage applied across the gel.
- After the set amount of time, the biomolecules will have migrated different distances based on their size.
- Smaller biomolecules travel farther down the gel, while larger ones remain closer to the point of origin.
- Biomolecules may therefore be separated roughly according to size, which depends mainly on molecular weight under denaturing conditions, but also depends on higher-order conformation under native conditions.

4. Detection

- Following electrophoresis, the gel may be stained (for proteins, most commonly with Coomassie Brilliant Blue or autoradiography; for nucleic acids, ethidium bromide; or for either, silver stain), allowing visualization of the separated proteins, or processed further (e.g. Western blot).
- After staining, different species biomolecules appear as distinct bands within the gel.
- It is common to run molecular weight size marker of known molecular weight in a separate lane in the gel to calibrate the gel and determine the approximate molecular mass of unknown biomolecules by comparing the distance traveled relative to the marker.

Applications of Polyacrylamide Gel Electrophoresis (SDS-PAGE)

- Measuring molecular weight.
- Peptide mapping.
- Estimation of protein size.
- Determination of protein subunits or aggregation structures.
- Estimation of protein purity.
- Protein quantitation.
- Monitoring protein integrity.
- Comparison of the polypeptide composition of different samples.
- Analysis of the number and size of polypeptide subunits.
- Post-electrophoresis applications, such as Western blotting.
- Staining of Proteins in Gels with Coomassie G-250 without Organic Solvent and Acetic Acid.
- Pouring and Running a Protein Gel by reusing Commercial Cassettes.
- Selective Labelling of Cell-surface Proteins using CyDye DIGE Fluor Minimal Dyes.
- Detection of Protein Ubiquitination.

Advantages of Polyacrylamide Gel Electrophoresis (SDS-PAGE)

- Stable chemically cross-linked gel
- Greater resolving power (Sharp bands)
- Can accommodate larger quantities of DNA without significant loss in resolution
- The DNA recovered from polyacrylamide gels is extremely pure

- The pore size of the polyacrylamide gels can be altered in an easy and controllable fashion by changing the concentrations of the two monomers.
 - Good for separation of low molecular weight fragments
-

Disadvantages of Polyacrylamide Gel Electrophoresis (SDS-PAGE)

- Generally more difficult to prepare and handle, involving a longer time for preparation than agarose gels.
- Toxic monomers
- Gels are tedious to prepare and often leak
- Need new gel for each experiment

2-Dimensional PAGE (2D-PAGE)

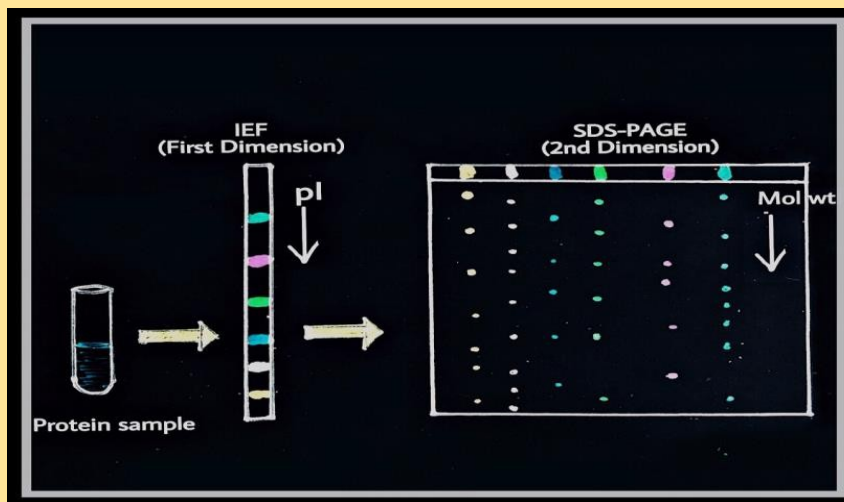

2D-PAGE

The topic for today is **2-Dimensional Polyacrylamide Gel Electrophoresis (2-D PAGE)**, a technique to separate different proteins in a given sample. It is used to study the entire **proteome** of a cell. Today we shall understand the principle and the entire technique in brief. The next few following blogs we shall see each step in detail.

Before starting with the 2-D PAGE, it is really necessary to know the about the SDS- Polyacrylamide Gel Electrophoresis (SDS-PAGE) and Isoelectric focussing electrophoresis.

– SDS-Polyacrylamide Gel Electrophoresis (SDS-PAGE):

To begin with, **Electrophoresis** literally means the movement of charged particles in a fluid or gel under the influence of the electric field. Electrophoresis was initially carried out in free solutions, later the solid supports were used, and with further development, now a days it is carried out in the gel networks like agarose and polyacrylamide gel.

Polyacrylamide gels are formed by the polymerization of acrylamide with small amount of N, N' methylene bisacrylamide in presence of TEMED and APS. Polyacrylamide gels are more stronger and more suitable for the separation of proteins and nucleic acids according to their size or size/charge ratio. The electrophoresis carried out in Polyacrylamide gel is termed as Polyacrylamide Gel Electrophoresis (PAGE).

Many proteins are folded into compact structures, held together by a variety of non-covalent, ionic interactions such as hydrogen bonding and salt bridges. Such ionic bonds can be disrupted to denature the proteins and then the denatured proteins are separated. This step gives important structural information about the proteins.

Sodium dodecyl sulphate (SDS), an anionic detergent, can disrupt the folded structure of the protein. SDS consists of a 12-Carbon chain and a polar sulphated head. It binds non-covalently to proteins, with a stoichiometry of around one SDS molecule per two amino acids. SDS causes proteins to denature and dissociate from each other (excluding covalent cross-linking). It also confers a negative charge, hence in the presence of SDS, the intrinsic charge of a protein is masked. During SDS PAGE, all proteins migrate toward the anode (the positively charged electrode). SDS-treated proteins have very similar charge-to-mass ratios and shapes. Therefore during PAGE, the rate of migration of SDS-treated proteins are determined by its molecular weight solely. This technique is called SDS- PAGE.

The isoelectric point (pI) is the specific pH at which the net charge of the protein is zero (zwitterion), that is there are equal number of positive and negative charges, and not that there are no charges. Proteins are positively charged (cation) at pH values below their pI and negatively charged (anion) at pH values above their pI. If the pH of the electrophoretic medium is identical to the pI of a protein, the protein has a net charge of zero and does not migrate toward either electrode, that the pull from both the electrodes are of equal strength. Hence if a mixture of proteins is run in a gradient of pH, the individual proteins will cease to move whenever the pH is identical to their pI, thus getting separated on the basis of their pI. This technique of separating proteins is called Isoelectric focussing (IEF).

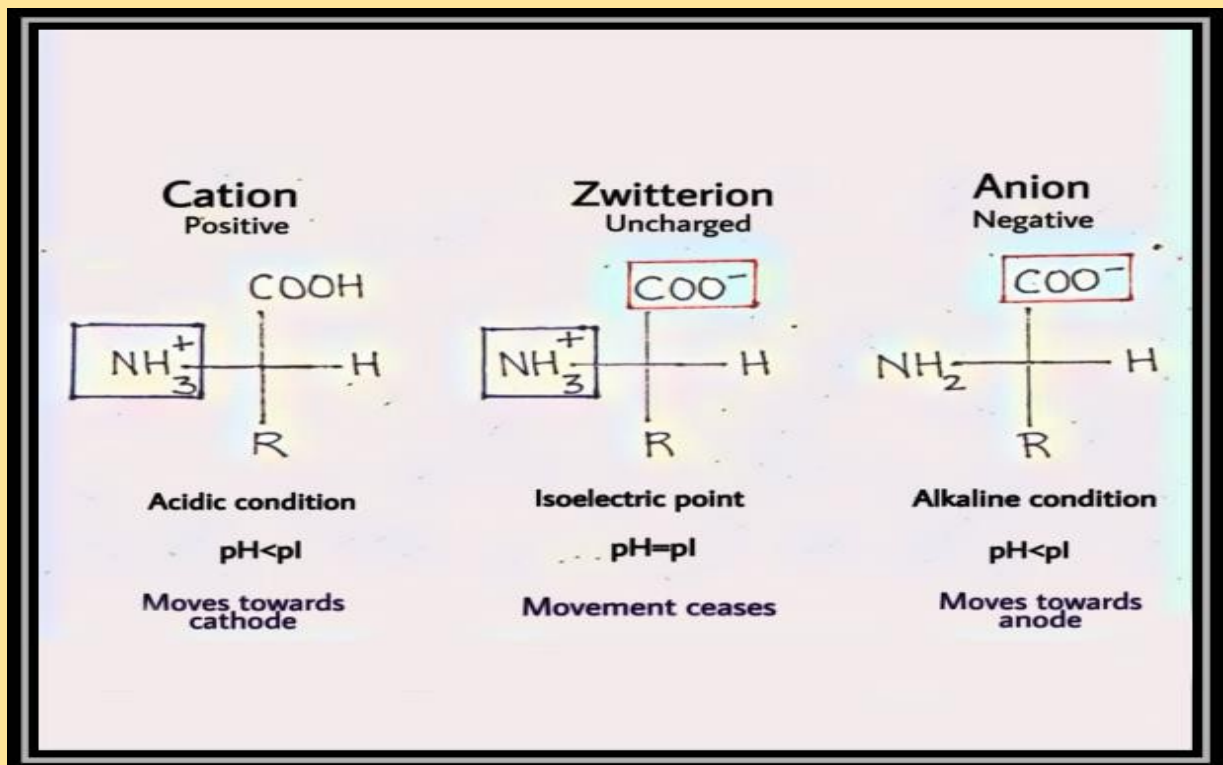

Fig 1: Characteristics of protein at different pH conditions
 Now with this information, we can put together the **2-D PAGE**....

2-D PAGE or 2-DE is a technique which can give enhanced resolution of complex protein mixtures. It is a powerful tool for researchers in the field of **proteomics**, to study the structure, interactions, and biological function of the proteins expressed by the genome (proteome) of an organism. It was first reported by P.H. O'Farrell in 1975. In 2DE the protein mixture is first separated by Isoelectric focussing and then the separated proteins (each band) are further separated by SDS- PAGE.

As previously mentioned, in the first dimension, that is IEF, the proteins are separated according to their **isoelectric point** (pI). IEF of the protein sample is performed on a thin strip. After the completion of IEF, the strip is run perpendicular to the first run along the SDS- PAGE gel, the second dimension, wherein the proteins with similar pI (grouped together) are further separated on the basis on their molecular weight on SDS-PAGE gel (see fig 2).

Hence all the protein are separated twice, with second run perpendicular to the first one, as shown in figure. The proteins in the SDS-PAGE gel shown in same color (in fig 2) have same/similar pI.

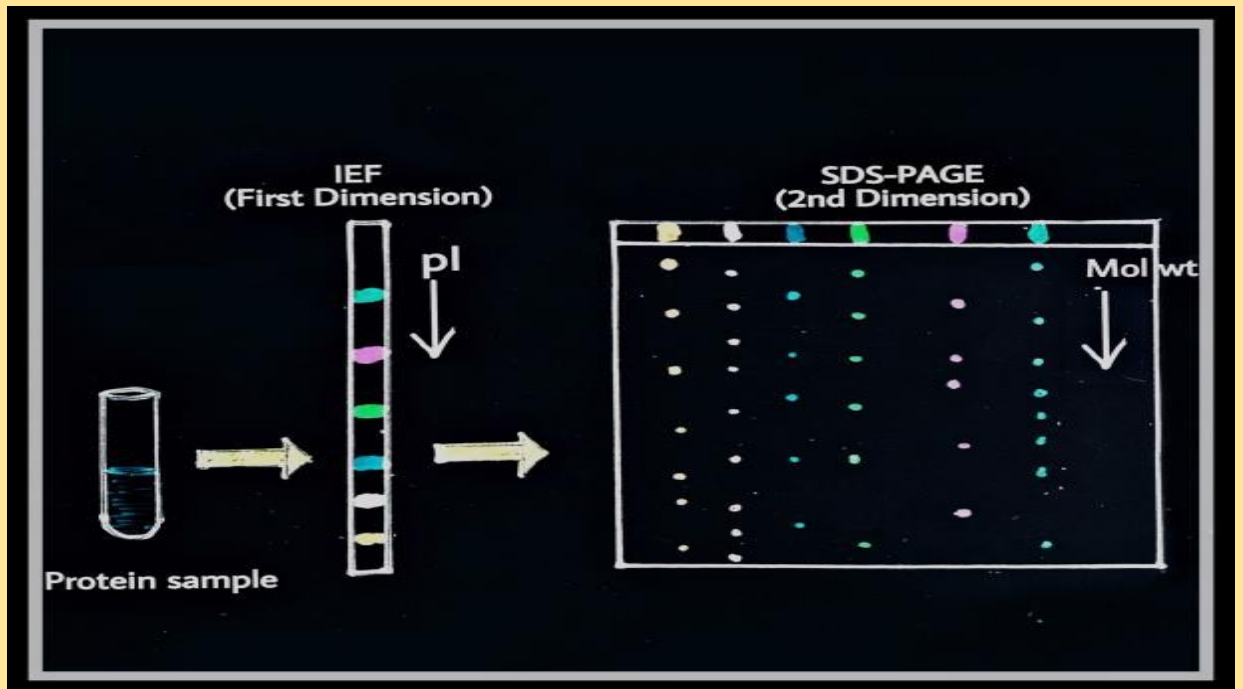

Fig 2: 2D-PAGE

Every **spot** on the gel correspond to a single protein type, and thousand such protein spots will be obtained. The increase or decrease in **intensity** of a spot representing a specific protein may be monitored as a function of **cell function**.

However with thousands of spots, the **analysis** is complex, time-consuming and difficult. But with recent developments, the data can be analysed using modern computer **software** and online protein **databases**.

Experimentally the entire process is carried out in different steps:

1. Sample preparation
2. IPG strip rehydration
3. IEF
4. IPG strip equilibration
5. SDS-PAGE
6. Visualization
7. Analysis

The proteins separated by 2-DE can be further analyzed by **mass spectrometer** and partial protein **sequence** data can be obtained.

Zymography

Zymography is an electrophoretic technique for the detection of hydrolytic enzymes, based on the substrate repertoire of the enzyme. Three types of zymography are used; *in gel* zymography, *in situ* zymography and *in vivo* zymography.^[2] For instance, gelatin embedded in a polyacrylamide gel will be digested by active gelatinases run through the gel. After Coomassie staining, areas of degradation are visible as clear bands against a darkly stained background.^[3]

Modern usage of the term **zymography** has been adapted to define the study and cataloging of fermented products, such as beer or wine, often by specific brewers or winemakers or within an identified category of fermentation such as with a particular strain of yeast or species of bacteria. **Zymography** also refers to a collection of related, fermented products, considered as a body of work. For example, all of the beers produced by a particular brewery could collectively be referred to as its zymography.

See also Zymology or the applied science of zymography. Zymology relates to the biochemical processes of fermentation, especially the selection of fermenting yeast and bacteria in brewing, winemaking, and other fermented foods. For example, beer-making involves the application of top (ale) or bottom fermenting yeast (lager), to produce the desired variety of beer. The synthesis of the yeast can impact the flavor profile of the beer, i.e. diacetyl (taste or aroma of buttery, butterscotch)

Gel zymography

Samples are prepared in a standard, non-reducing loading buffer for SDS-PAGE. No reducing agent or boiling are necessary since these would interfere with refolding of the enzyme. A suitable substrate (e.g. gelatin or casein for protease detection) is embedded in the resolving gel during preparation of the acrylamide gel. Following electrophoresis, the SDS is removed from the gel (or **zymogram**) by incubation in unbuffered Triton X-100, followed by incubation in an appropriate digestion buffer, for an optimized length of time at 37 °C. The zymogram is subsequently stained (commonly with Amido Black or Coomassie Brilliant Blue), and areas of digestion appear as clear bands against a darkly stained background where the substrate has been degraded by the enzyme.

Variations on the standard protocol

The standard protocol may require modifications depending on the sample enzyme; for instance, *D. melanogaster* digestive glycosidases generally survive reducing conditions (i.e. the presence of 2-mercaptoethanol or DTT), and to an extent, heating. Indeed, the separations following heating to 50 °C tend to exhibit a substantial increase in band resolution, without appreciable loss of activity.^{[4][5]}

A common protocol used in the past for zymography of α -amylase activity was the so-called starch film protocol of W.W. Doane. Here a native PAGE gel was run to separate the proteins in a homogenate. Subsequently, a thin gel with starch dissolved (or more properly, suspended) in it was overlaid for a period of time on top of the original gel.^[6] The starch was then stained with Lugol's iodine.

Gel zymography is often used for the detection and analysis of enzymes produced by microorganisms.^[7] This has led to variations on the standard protocol e.g. mixed-substrate zymography.^[2]

Reverse zymography copolymerizes both the substrate and the enzyme with the acrylamide, and is useful for the demonstration of enzyme inhibitor activity. Following staining, areas of inhibition are visualized as dark bands against a clear (or lightly stained) background.

In imprint technique, the enzyme is separated by native gel electrophoresis and the gel is laid on top of a substrate treated agarose.^[1]

Zymography can also be applied to other types of enzymes, including xylanases, lipases and chitinases.

Colorimetry: Principle and Instruments

Principle of Colorimetry:

Colorimetry is a widely used technique applied in biological system. It involves the measurement of a compound or a group of compounds present in a complex mixture. The property of colorimetric analyses is to determine the intensity or concentration of compounds in coloured solution.

This is done by passing light of specific wavelength of visible spectrum through the solution in a photoelectric colorimeter instrument and observe the galvanometric reading of reflection sensitizing the quantity of light absorbed.

Based on the nature of colour compounds, specific light filters are used. Three types of filters are available — blue, green and red — with corresponding light wavelength transmission rays from 470-490 nm, 500-530 nm and 620-680 nm, respectively.

There are two fundamental laws of absorption which are highly important in colorimetric estimation. These are Lambert's law and Beer's law. Lambert's law states that when monochromatic light passes through a solution of constant concentration, the absorption by the solution is directly proportional to the length of the solution.

In contrary, Beer's law states that when monochromatic light passes through a solution of constant length, the absorption by the solution is directly proportional to the concentration of the solution.

Thus both the laws can be expressed as:

Lambert's law: $\log_{10} I_0/I = K_1 l$

Beer's law: $\log_{10} I_0/I = K_2 c$

[where I_0 = Intensity of incident light (light entering a solution);

I = Intensity of transmitted light (light leaving a solution);

l = Length of absorbing solution;

c = Concentration of coloured substance in solution;

K_1 and K_2 = Constants.]

Both Beer-Lambert law are combined together for getting the expression transmittance (T).

$$T = I/I_0$$

(where I_0 is the intensity of incident radiation and I is the intensity of transmitted radiation).

A 100% value of 'T' represent a totally transparent substance, with no radiation being aborted, whereas a zero value of 'T' represents a totally opaque substance that, in effect, represents complete absorption. For intermediate value we can define the absorbance (A) or extinction (E) that is given by the logarithm (to base 10) of the reciprocal of the transmittance:

$$A = E = \log_{10} (I_0/I) = \log_{10} (1/T)$$

Absorbance used to be called optical density (OD) but continued use of this term should be discouraged. Also, as absorbance is a logarithm it is, by definition, unit-less and has a range of values from 0 (= 100% T) to ∞ (= 0% T).

Thus the variation of colour of the reaction mixture (or system) with change of substrate concentration forms the basis of colorimetric analysis.

The formation of colour is due to the reaction between substances and reagents in appropriate proportion. The intensity of colour observed is then compared with that of reaction mixture which contains a known amount of substrate. The optical spectrophotometry is based on identical principles of colorimetry.

Instruments of Colorimetry:

(A) Colorimeter:

The colorimeter instrument is very simple, consisting merely of a light source (lamp), filter, cuvette and photosensitive detector to collect the transmitted light. Another detector is required to measure the incident light; or a single detector may be used to measure incident and transmitted light, alternately.

The latter design is both cheaper and analytically better, because it eliminates variations between detectors. The filter is used here to obtain an appropriate range of wavelengths within the bands which it is capable of selecting.

A colorimeter is a device used in colorimetry that measures the absorbance of particular wavelengths of light by a specific solution.[1] It is commonly used to determine the concentration of a known solute in a given solution by the application of the Beer-Lambert law, which states that the concentration of a solute is proportional to the absorbance

Construction

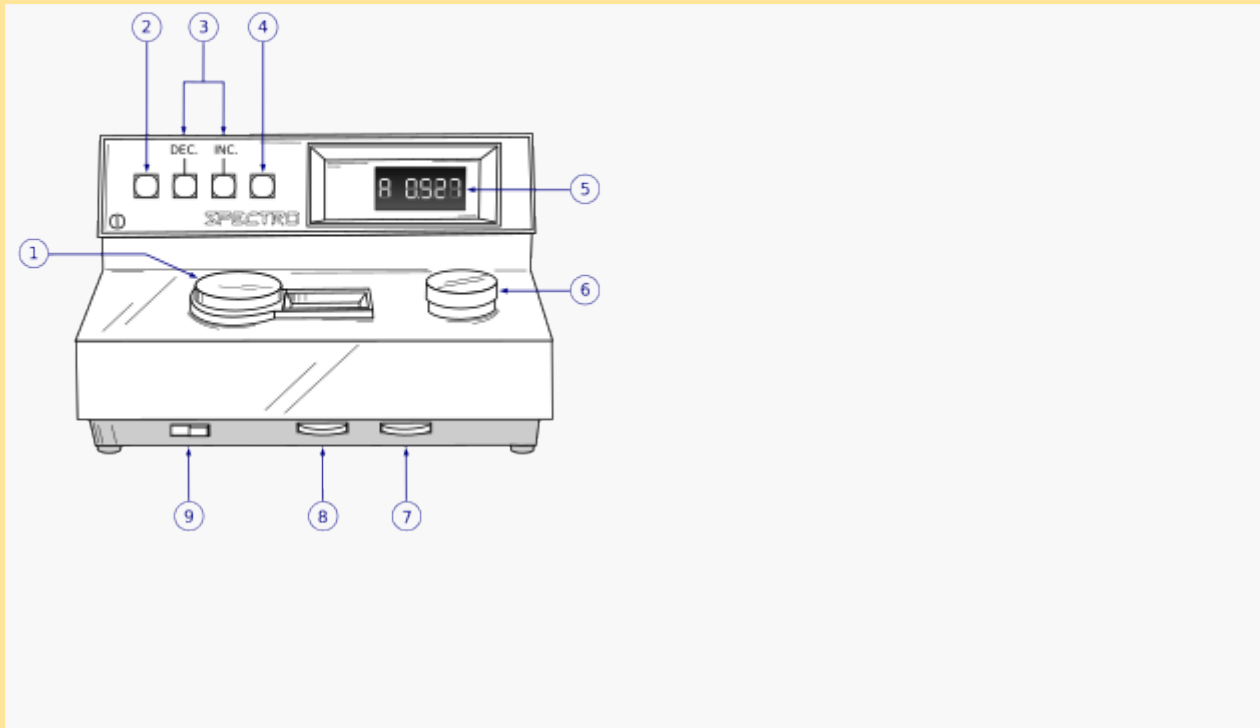

The essential parts of a colorimeter are:

- a **light source** (often an ordinary low-voltage filament lamp);
- an adjustable aperture;
- a set of colored filters;
- a cuvette to hold the working solution;
- a detector (usually a photoresistor) to measure the transmitted light;
- a meter to display the output

from the detector. In addition, there may be:

- a voltage regulator, to protect the instrument from fluctuations in mains voltage;
- a second light path, cuvette and detector. This enables comparison between the working solution and a "blank", consisting of pure solvent, to improve accuracy.

There are many commercialized colorimeters as well as open source versions with construction documentation for education and for research.^[3]

Filters

Changeable optics filters are used in the colorimeter to select the wavelength which the solute absorbs the most, in order to maximize accuracy. The usual wavelength range is from 400 to 700 nm. If it is necessary to operate in the ultraviolet range then some modifications to the colorimeter are needed. In modern colorimeters the filament lamp and filters may be replaced by several (light-emitting diode) of different colors. The Measurement of Colour.

Cuvettes

In a manual colorimeter the cuvettes are inserted and removed by hand. An automated colorimeter (as used in an AutoAnalyzer) is fitted with a **flowcell** through which solution flows continuously.

Output

The output from a colorimeter may be displayed by an analogue or digital meter and may be shown as transmittance (a linear scale from 0-100%) or as absorbance (a logarithmic scale from zero to infinity). The useful range of the absorbance scale is from 0-2 but it is desirable to keep within the range 0-1 because, above 1, the results become unreliable due to scattering of light.

In addition, the output may be sent to a chart recorder, data logger, or computer.

(A) Spectrophotometer:

It is a more sophisticated instrument. A photometer is a device for measuring 'light', and 'spectro' implies the whole range of continuous wavelengths that the light source is capable of producing. The detector in the photometer is generally a photo cell in which a sensitive surface receives photons; and a current is generated that is proportional to the intensity of the light beam, reaching the surface.

In instruments for measuring ultraviolet/visible light, two lamps are usually required: one, a tungsten filament lamp which produces wavelengths in the visible region; the second, a hydrogen or deuterium lamp, is suitable for the ultraviolet.

There are two kinds of optical arrangements: a single-beam or a double beam type. Here, first the blank and then the sample must be moved into the beam, adjustments made and readings taken.

The details of optical arrangement in Spectrophotometer is given:

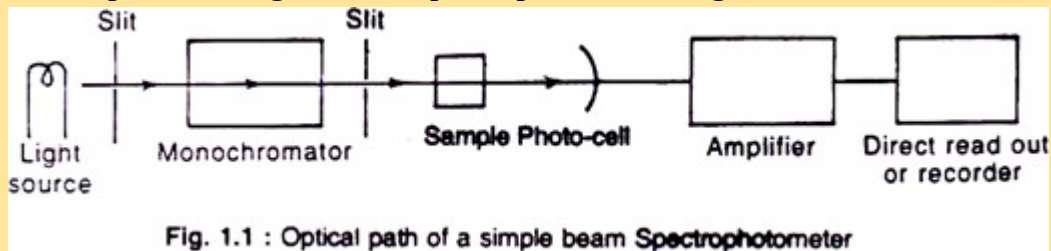

The major advantage of the spectrophotometer, however, is the facility to scan the wavelength range over both ultraviolet and visible light and obtain absorption spectra.

A large number of inorganic and organic compounds were quantitatively estimated by the use of colorimetric or optical spectrophotometric techniques:

Substance	Reagent	Wavelength (nm)
Inorganic phosphate	Ammonium molybdate; H_2SO_4 ; 1, 2, 4-aminonaphthol; $NaHS_4$, Na_2SO_3	600
Amino acids	(a) Ninhydrin	570 (proline 420)
	(b) Cupric salts	620
Peptide bonds	Biuret (alkaline tartrate buffer, cupric salt)	540
Phenols, tyrosine	Folin (phosphomolybdate, Phosphotungstate, cupric salt)	660 or 750 (750 more sensitive)
Protein	(a) Folin	660
	(b) Biuret	540
	(c) BCA reagent (Bicinchoninic Acid)	562
	(d) Coomassie Brilliant Blue	595
Carbohydrate	(a) Phenol, H_2SO_4	Varies, e.g., glucose 490, xylose 480
	(b) Anthrone (anthrone, H_2SO_4)	620 or 625
Reducing sugars	Dinitrosalicylate, alkaline tartrate buffer	540
Pentoses	(a) Bial (orcinol, ethanol, $FeCl_3$, HCl)	665
	(b) Cysteine, H_2SO_4	380-415
Hexoses	(a) Carbazole, ethanol, H_2SO_4	540 or 440
	(b) Cysteine, H_2SO_4	380-415
	(c) Arsenomolybdate	Usually 500-570
Glucose	Glucose oxidase, peroxidase, α -dianisidine, phosphate buffer	420
Ketohexose	(a) Resorcinol, thiourea, ethanoic acid, HCl	520
	(b) Carbazole, ethanol, cysteine H_2SO_4	560
	(c) Diphenylamine, ethanol, ethanoic	635
Hexosamines	Ehrlich (dimethylaminobenzaldehyde, ethanol, HCl)	530
DNA	Diphenylamine	600
RNA	Bial (orcinol, ethanol, $FeCl_3$, HCl)	665
α -Oxo acids	Dinitrophenylhydrazine, Na_2CO_3 , ethyl acetate	435
Sterols	Liebermann-Burchardt reagent (acetic anhydride, H_2SO_4 , chloroform)	625
Steroid hormones	Liebermann-Burchardt reagent	425
Cholesterol	Cholesterol oxidase, peroxidase, 4-aminoantipyrine, phenol	500

Turbidometry and Nephelometry

When particles are suspended in a solution in a cuvette, they make the solution unclear (turbid). Incident light entering the cuvette will be subjected to three reactions;

- 1- some of the light will be absorbed (blocked) by the particles
- 2- some will be transmitted through the cuvette
- 3- some will be scattered in various directions.

Turbidimetry

- Turbidimetry is involved with measuring the amount of transmitted light (and calculating the absorbed light) by particles in suspension to determine the concentration of the substance in question. Amount of absorbed light, and therefore, concentration is dependent on ; a) number of particles, and 2) size of particles.
- Measurements are made using light spectrophotometers Clinical

Applications

- Determination of the concentration of total protein in biological fluids such as urine and CSF which contain small quantities of protein (mg/L quantities) using trichloroacetic acid
- Determination of amylase activity using starch as substrate. The decrease in turbidity is directly proportional to amylase activity.
- Determination of lipase activity using triglycerides as substrate. The decrease in turbidity is directly proportional to lipase activity.

Principle :

- Nephelometry is concerned with measurement of scattered light from a cuvette containing suspended particles in a solution.
- The components of a nephelometer are the same as a light spectrophotometer except that the detector is placed at a specific angle from the incident light.
- The detector is a photomultiplier tube placed at a position to detect forward scattered light. Detectors may be placed at 90° , 70° or 37° depending on the angle at which most

scattered light are found.

- Since the amount of scattered light is far greater than the transmitted light in a turbid suspension, nephelometry offers higher sensitivity than turbidimetry.
- The amount of scattered light depends on the size and number of particles in suspension.
- For most clinical applications, the light source is a tungsten lamp giving light in the visible region
- For higher sensitivity and for applications that determine the size and number of particles in suspension, laser light nephelometers are used.

Clinical applications of nephelometry.

- Widely used to determine concentrations of unknowns where there is antigen-antibody reactions such as
 - o Determination of immunoglobulins (total, IgG, IgE, IgM, IgA) in serum and other biological fluids
 - o Determination of the concentrations of individual serum proteins; hemoglobin, haptoglobin, transferrin, c-reactive protein, 1-antitrypsin, albumin (using antibodies specific for each protein)
- Determination of the size and number of particles (laser-nephelometry)

Considerations in turbidimetry and nephelometry

- The reaction in turbidimetry & nephelometry does not follow Beer's Law
- Therefore, standard curves must be plotted and the concentration of the unknown is determined from the standard curve.
- Because the absorbance is dependent on both number and size of particles, the standard solution which is used for the standard curve must have similar size in suspension as unknown.
- Because some precipitation and settlement of particles may occur with time, in order to obtain good accuracy it is important to ; a) mix the sample well prior to placing the cuvette in the instrument, and, b) keep the same time for measurement of every sample throughout the measurement.
- Kinetic reactions (measurement of the progress of reaction with time) provides higher degree of accuracy, sensitivity, precision and less time than end-point reactions (measuring the reaction at the start and finish of the reaction)
 - o Additionally in kinetic reactions there is no need for reagent blank since the previous reading is taken as the base-line for the next reading.
 - o Kinetic reaction may be taken in 60, 90 or 120 seconds (taking readings at 10 seconds intervals), whereas endpoint reactions may take much longer time e.g. 15 - 120 minutes.
- Selection of a wavelength
 - If both solution and suspended particles are colorless, then use any wave length in the visible range
 - If the solution is coloured but the particles are not coloured, then use a wave length that gives minimum absorption for the solution
 - If the particles are coloured and the solution is colorless then use a wavelength that gives maximum absorption with the particles
 - If both solution and particles are coloured then use two wavelengths; one that gives minimum absorbance for the solution and the other one maximum absorbance for the particles. Subtract the solution absorbance from the particles absorbance.

UV-Visible Spectrophotometer

A spectrophotometer is an instrument used to measure absorbance at various wavelengths. It is similar to calorimeter except that it uses prism or diffraction grating to produce monochromatic light. It can be operated in UV (Ultraviolet) region, Visible spectrum as well as IR (Infrared) region of the electromagnetic spectrum.

⇒ **Absorption of light** – Light falling on a colored solution is either absorbed or transmitted. A colored solution absorbs all the colors of white light and selectively transmits only one color. This is its own color.

PRINCIPLE OF SPECTROPHOTOMETER

Spectrophotometer is based on the photometric technique which states that When a beam of incident light of intensity I_0 passes through a solution, a part of the incident light is reflected (I_r), a part is absorbed (I_a) and rest of the light is transmitted (I_t)

Thus,

$$I_0 = I_r + I_a + I_t$$

⇒ In photometers (colorimeter & spectrophotometer), (I_r) is eliminated because the measurement of (I_0) and I_t is sufficient to determine the (I_a). For this purpose, the amount of light reflected (I_r) is kept constant by using cells that have identical properties. (I_0) & (I_t) is then measured.

⇒ The mathematical relationship between the amount of light absorbed and the concentration of the substance can be shown by the two fundamental laws of photometry on which the Spectrophotometer is based.

Check out the Principle, Working & Uses of Colorimeter in Laboratory

Beer's Law

⇒ This law states that the amount of light absorbed is directly proportional to the concentration of the solute in the solution.

$$\text{Log}_{10} I_0/I_t = a_s c$$

where,

a_s = Absorbency index

c = Concentration of Solution

Lambert's Law

⇒ The Lambert's law states that the amount of light absorbed is directly proportional to the length and thickness of the solution under analysis.

$$A = \log_{10} I_0/I_t = a_s b$$

Where,

A = Absorbance of test

a_s = Absorbance of standard

b = length / thickness of the solution

The mathematical representation of the combined form of Beer-Lambert's law is as follows:

$$\text{Log}_{10} I_0 / I_t = a_s b c$$

If b is kept constant by applying Cuvette or standard cell then,

$$\text{Log}_{10} I_0 / I_t = a_s c$$

The absorbency index a_s is defined as

$$a_s = A / c l$$

Where,

c = concentration of the absorbing material (in gm/liter). l =

distance traveled by the light in solution (in cm).

In simplified form,

The working principle of the Spectrophotometer is based on Beer-Lambert's law which states that the amount of light absorbed by a color solution is directly proportional to the concentration of the solution and the length of a light path through the solution.

$$A \propto c l$$

Where,

A = Absorbance / Optical density of solution c =

Concentration of solution

l = Path length

or,

$$A = \epsilon c l$$

ϵ = Absorption coefficient

TYPES OF SPECTROPHOTOMETER

Spectrophotometer is of 2 types –

- Single beam spectrophotometer
- Double beam spectrophotometer

Single beam spectrophotometer operates between 325 nm to 1000 nm wavelength using the single beam of light. The light travels in one direction and the test solution and blank are read in the same.

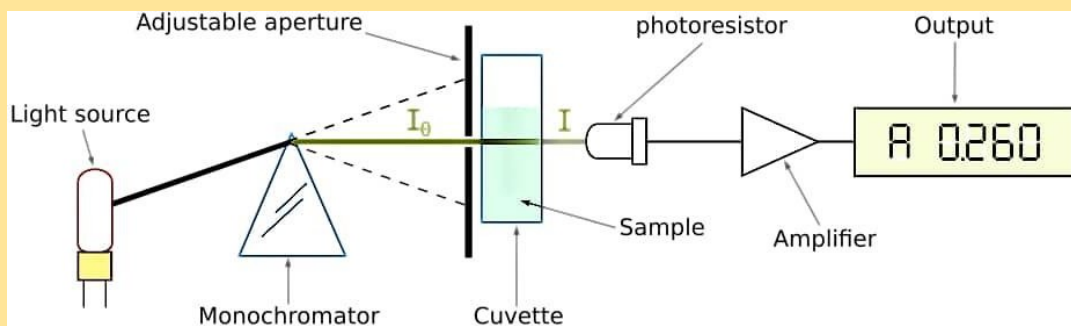

SINGLE BEAM SPECTROPHOTOMETER

Double beam spectrophotometer operates between 185 nm to 1000 nm wavelength. It has two photocells. This instrument splits the light from the Monochromator into two beams. One beam is used for reference and the other for sample reading. It eliminates the error which occurs due to fluctuations in the light output and the sensitivity of the detector.

Check out the Preparation of Normal Saline solution in Laboratory

PARTS OF SPECTROPHOTOMETER

There are 7 essential parts of a spectrophotometer

Light source – In spectrophotometer three different sources of light are commonly used to produce light of different wavelength. The most common source of light used in the spectrophotometer for the visible spectrum is a tungsten lamp. For **Ultraviolet radiation**, commonly used sources are the hydrogen lamp and the deuterium lamp. Nernst filament or globar is the most satisfactory sources of **IR (Infrared) radiation**.

Monochromator – To select the particular wavelength, prism or diffraction grating is used to split the light from the light source.

Sample holder – Test tube or Cuvettes are used to hold the colored solutions. They are made up of glass at a visible wavelength.

Beam splitter – It is present only in double beam spectrophotometer. It is used to split the single beam of light coming from the light source into two beams.

Mirror – It is also present only in double beam spectrophotometer. It is used to reflect the light from the beam splitter.

Photodetector system – When light falls on the detector system, an electric current is generated that reflects the galvanometer reading.

Measuring device – The current from the detector is fed to the measuring device – the galvanometer. The meter reading is directly proportional to the intensity of light.

WORKING OF THE SPECTROPHOTOMETER

⇒ When using a Spectrophotometer, it requires being calibrated first which is done by using the standard solutions of the known concentration of the solute that has to be determined in the test solution. For this, the standard solutions are filled in the Cuvettes and placed in the Cuvette holder in the spectrophotometer that is similar to the colorimeter.

⇒ There is a ray of light with a certain wavelength that is specific for the assay is directed towards the solution. Before reaching the solution the ray of light passes through a series of the diffraction grating, prism, and mirrors. These mirrors are used for navigation of the light in the spectrophotometer and the prism splits the beam of light into different wavelength and the diffraction grating allows the required wavelength to pass through it and reaches the Cuvette containing the standard or Test solutions. It analyzes the reflected light and compares with a predetermined standard solution.

⇒ When the monochromatic light (light of one wavelength) reaches the Cuvette some of the light is reflected, some part of the light is absorbed by the solution and the remaining part is transmitted through the solution which falls on the photodetector system. The photodetector system measures the intensity of transmitted light and converts it into the electrical signals that are sent to the galvanometer.

⇒ The galvanometer measures the electrical signals and displays it in the digital form. That digital representation of the electrical signals is the absorbance or optical density of the solution analyzed.

⇒ If the absorption of the solution is higher than there will be more light absorbed by the solution and if the absorption of the solution is low then more lights will be transmitted through the solution which affects the galvanometer reading and corresponds to the concentration of the solute in the solution. By putting all the values in the formula given in the below section one can easily determine the concentration of the solution.

⇒ In double beam spectrophotometers, the beam splitters are present which splits the monochromatic light into two beams one for the standard solution and the other for test solution. In this, the absorbance of Standard and the Test solution can be measured at the same time and any no. of test solutions can be analyzed against one standard. It gives more accurate and precise results, eliminates the errors which occur due to the fluctuations in the light output and the sensitivity of the detector.

APPLICATIONS OF THE SPECTROPHOTOMETER

⇒ The spectrophotometer is commonly used for the determination of the concentration of colored as well as colorless compounds by measuring the optical density or its absorbance.

⇒ It can also be used for the determination of the course of the reaction by measuring the rate of formation and disappearance of the light absorbing compound in the range of the visible & UV region of electromagnetic spectrum.

⇒ By spectrophotometer, a compound can be identified by determining the absorption spectrum in the visible region of the light spectrum as well as the UV region of the electromagnetic spectrum.

Flame Photometry

Flame Photometry is also called as flame emission spectroscopy. Flame Photometry is branch of atomic spectroscopy. It is used to detected certain metal ions like sodium,potassium,magenisum etc.

PRINCIPLE :-

Sample is sprayed into a flame and it converted to droplets. Due to the thermal energy of the flame the solvent in the droplets evaporate, leaving behind fine residue, which are converted to neutral atoms. This neutral atoms are get energy form thermal energy and go excited state but they are unstable at excited state so they are return to ground state with emission of specific wave length radiation. The wavelength of the radiation emitted is characteristic of the elements and is used to identify the elements (Qualitative Analysis). The intensity of the radiation emitted depends upon the concentration of the element analysed (Quantitative Analysis).

Liquid sample

↓ Formation of droplets

↓

Fine residue

↓

Formation of neutral atoms

↓

Excitation of atoms by thermal energy

↓

Emission of radiation of specific wavelength

↓

λ & Intensity of emitted radiation measured

The wavelength of the radiation emitted is given by the following equation :-

$$\lambda = hc / E_2 - E_1$$

Where,

h = Planks constant

c = Velocity of light

E_2, E_1 = energy levels of excited and ground state respectively

BOLTZMAN LAW

The fraction of free atom that are thermally excited is governed by a Boltzman Distribution

$$N^* / N = Ae^{-\Delta E/kT}$$

- N^* = is the number of excited atom
- N = is the number of atom remaining in the ground state
- ΔE = is the difference in energies levels
- k = The Boltzman constant
- T = the temperature

INSTRUMENTATION OF A FLAME PHOTOMETER :-

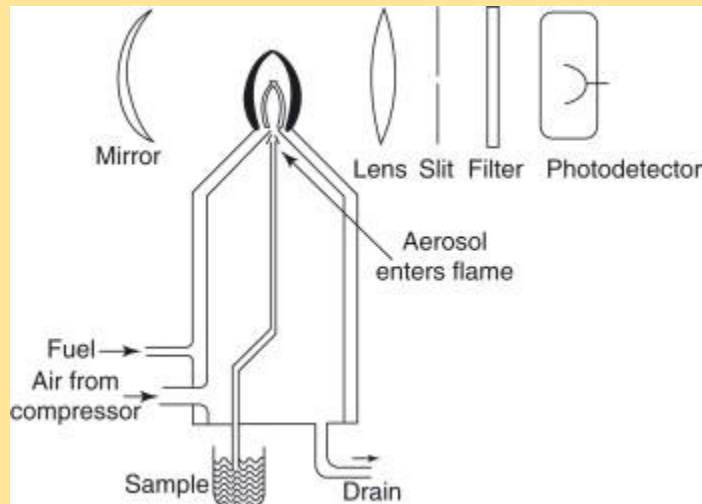

COMPONENTS OF A FLAME PHOTOMETER

1. Burner (With fuel and oxidant)
2. Filter/Monochromator
3. Detector
4. Read out device

1. Burner :-

There are different burners available which are used to spray the sample solution into fine droplet mix with fuel and oxidant so that a homogenous flame of stable intensity is obtained. The most common ones are mecker burner, total consumption burner and laminar flow burner.

TOTAL CONSUMPTION BURNER

- Due to the high pressure of fuel and oxidant the sample solution is aspirated through capillary and burnt at the tip of burner
- Hydrogen and oxygen are generally employed as fuel and oxidant.
- The advantage over other is the entire consumption of sample,
- It's disadvantage is the production of non uniform flame and turbulent.

PREMIX BURNER

- In this burner the sample, fuel oxidant are thoroughly mixed before aspiration and reaching to flame
- The main advantage of it is the uniformity of flame produced.
- The main disadvantage is the heavy loss of mix up to 95%.

FUEL AND OXIDANTS :-

FUEL	AIR	OXYGEN
Propane	2100°C	2800°C
Hydrogen	1900°C	2800°C
Acetylene	2200°C	3000°C

2. FILTER / MONOCHROMATOR :-

In flame photometry the wavelength as well as intensity of the radiation emitted by the elements has to be monitored. Hence a filter or monochromator is to be used. A simple flame photometer contains a filter wheel and when a particular element has to be analysed the specific filter is selected.

3. DETECTOR :-

The radiation emitted by the elements is mostly in the visible region. Hence conventional detectors like photo voltaic cell or photo tubes can be used. In a flame spectrophotometer, photomultiplier tube is used as detector.

4. READ OUT DEVICE :-

The signal from the detector is shown as a response in the digital read out device. The readings are displayed in an arbitrary scale (% Flame Intensity).

APPLICATION :-

- To estimate sodium, potassium, calcium, lithium etc. level in sample of serum, urine, CSF and other body fluids.
- Flame photometry is useful for the determination of alkali and alkaline earth metals.
- Used in determination of lead in petrol.

- Used in the study of equilibrium constants involving in ion exchange resins.
- Used in determination of calcium and magnesium in cement.

Micronutrients analysis Atomic Absorption

Spectroscopy

There are many applications of atomic absorption spectroscopy (AAS) due to its specificity. These can be divided into the broad categories of biological analysis, environmental and marine analysis, and geological analysis.

Biological analysis

Biological samples can include both human tissue samples and food samples. In human tissue samples, AAS can be used to determine the amount of various levels of metals and other electrolytes, within tissue samples. These tissue samples can be many things including but not limited to blood, bone marrow, urine, hair, and nails. Sample preparation is dependent upon the sample. This is extremely important in that many elements are toxic in certain concentrations in the body, and AAS can analyze what concentrations they are present in. Some examples of trace elements that samples are analyzed for are arsenic, mercury, and lead.

An example of an application of AAS to human tissue is the measurement of the electrolytes sodium and potassium in plasma. This measurement is important because the values can be indicative of various diseases when outside of the normal range. The typical method used for this analysis is atomization of a 1:50 dilution in strontium chloride ($\text{SrCl}_2\text{SrCl}_2$) using an air-hydrogen flame. The sodium is detected at its secondary line (330.2 nm) because detection at the first line would require further dilution of the sample due to signal intensity. The reason that strontium chloride is used is because it reduces ionization of the potassium and sodium ions, while eliminating phosphate's and calcium's interference.

In the food industry, AAS provides analysis of vegetables, animal products, and animal feeds. These kinds of analyses are some of the oldest application of AAS. An important consideration that needs to be taken into account in food analysis is sampling. The sample should be an accurate representation of what is being analyzed. Because of this, it must be homogenous, and many it is often needed that several samples are run. Food samples are most often run in order to determine mineral and trace element amounts so that consumers know if they are consuming an adequate amount. Samples are also analyzed to determine heavy metals which can be detrimental to consumers.

Environmental and marine analysis

Environmental and marine analysis typically refers to water analysis of various types. Water analysis includes many things ranging from drinking water to waste water to sea water. Unlike biological samples, the preparation of water samples is governed more by laws than by the sample itself. The analytes that can be measured also vary greatly and can often include lead, copper, nickel, and mercury.

An example of water analysis is an analysis of leaching of lead and zinc from tin-lead solder into water. The solder is what binds the joints of copper pipes. In this particular experiment, soft water, acidic water, and chlorinated water were all analyzed. The sample preparation consisted of exposing the various water samples to copper plates with solder for various intervals of time. The samples were then analyzed for copper and zinc with air-acetylene flame AAS. A deuterium lamp was used. For the samples that had copper levels below 100 µg/L, the method was changed to graphite furnace electrothermal AAS due to its higher sensitivity.

Geological analysis

Geological analysis encompasses both mineral reserves and environmental research. When prospecting mineral reserves, the method of AAS used needs to be cheap, fast, and versatile because the majority of prospects end up being of no economic use. When studying rocks, preparation can include acid digestions or leaching. If the sample needs to have silicon content analyzed, acid digestion is not a suitable preparation method.

An example is the analysis of lake and river sediment for lead and cadmium. Because this experiment involves a solid sample, more preparation is needed than for the other examples. The sediment was first dried, then grounded into a powder, and then was decomposed in a bomb with nitric acid (HNO_3) and perchloric acid (HClO_4). Standards of lead and cadmium were prepared. Ammonium sulfate ($[\text{NH}_4][\text{SO}_4]$) and ammonium phosphate ($[\text{NH}_4][3\text{PO}_4]$) were added to the samples to correct for the interferences caused by sodium and potassium that are present in the sample. The standards and samples were then analyzed with electrothermal AAS.

Instrumentation

Atomizer

In order for the sample to be analyzed, it must first be atomized. This is an extremely important step in AAS because it determines the sensitivity of the reading. The most effective atomizers create a large number of homogenous free atoms. There are many types of atomizers, but only two are commonly used: flame and electrothermal atomizers.

Flame atomizer

Flame atomizers (Figure 1.4.101.4.10) are widely used for a multitude of reasons including their simplicity, low cost, and long length of time that they have been utilized. Flame atomizers accept an aerosol from a nebulizer into a flame that has enough energy to both volatilize and atomize the sample. When this happens, the sample is dried, vaporized, atomized, and ionized. Within this category of atomizers, there are many subcategories determined by the chemical composition of the flame. The composition of the flame is often determined based on the sample being analyzed. The flame itself should meet several requirements including sufficient energy, a long length, non-turbulent, and safe.

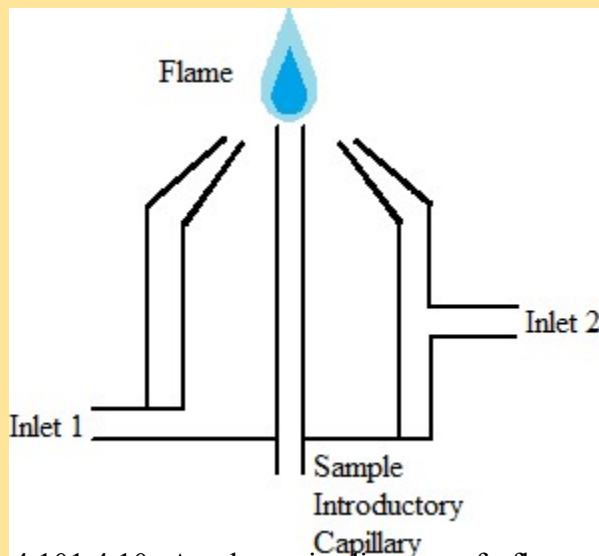

Figure 1.4.101.4.10: A schematic diagram of a flame atomizer showing the oxidizer inlet (1) and fuel inlet (2).

Electrothermal atomizer

Although electrothermal atomizers were developed before flame atomizers, they did not become popular until more recently due to improvements made to the detection level. They employ graphite tubes that increase temperature in a stepwise manner. Electrothermal atomization first dries the sample and evaporates much of the solvent and impurities, then atomizes the sample, and then rises it to an extremely high temperature to clean the graphite tube. Some requirements for this form of atomization are the ability to maintain a constant temperature during atomization, have rapid atomization, hold a large volume of solution, and emit minimal radiation. Electrothermal atomization is much less harsh than the method of flame atomization.

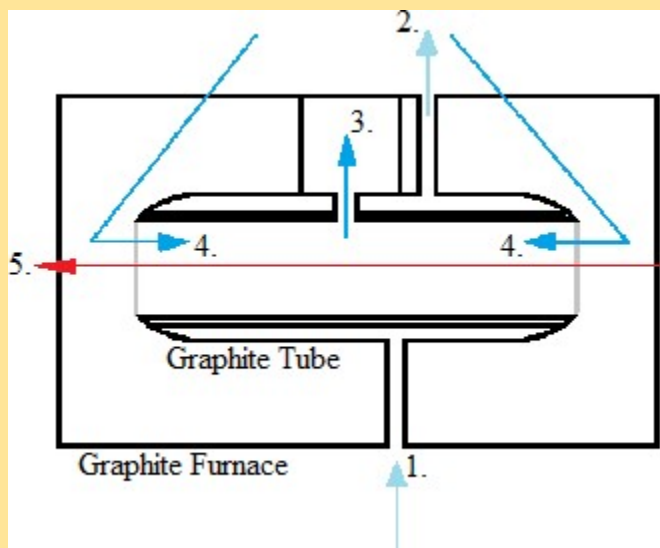

Figure 1.4.111.4.11: Schematic diagram of an electrothermal atomizer showing the external gas flow inlet (1), the external gas flow outlet (2), the internal gas flow outlet (3), the internal gas flow inlet (4), and the light beam (5).

Radiation source

The radiation source then irradiates the atomized sample. The sample absorbs some of the radiation, and the rest passes through the spectrometer to a detector. Radiation sources can be separated into two broad categories: line sources and continuum sources. Line sources excite the analyte and thus emit its own line spectrum. Hollow cathode lamps and electrodeless discharge lamps are the most commonly used examples of line sources. On the other hand, continuum sources have radiation that spreads out over a wider range of wavelengths. These sources are typically only used for background correction. Deuterium lamps and halogen lamps are often used for this purpose.

Spectrometer

Spectrometers are used to separate the different wavelengths of light before they pass to the detector. The spectrometer used in AAS can be either single-beam or double-beam. Single-beam spectrometers only require radiation that passes directly through the atomized sample, while double-beam spectrometers (Figure 1.4.121.4.12), as implied by the name, require two beams of light; one that passes directly through the sample, and one that does not pass through the sample at all. (Insert diagrams) The single-beam spectrometers have less optical components and therefore suffer less radiation loss. Double-beam monochromators have more optical components, but they are also more stable over time because they can compensate for changes more readily.

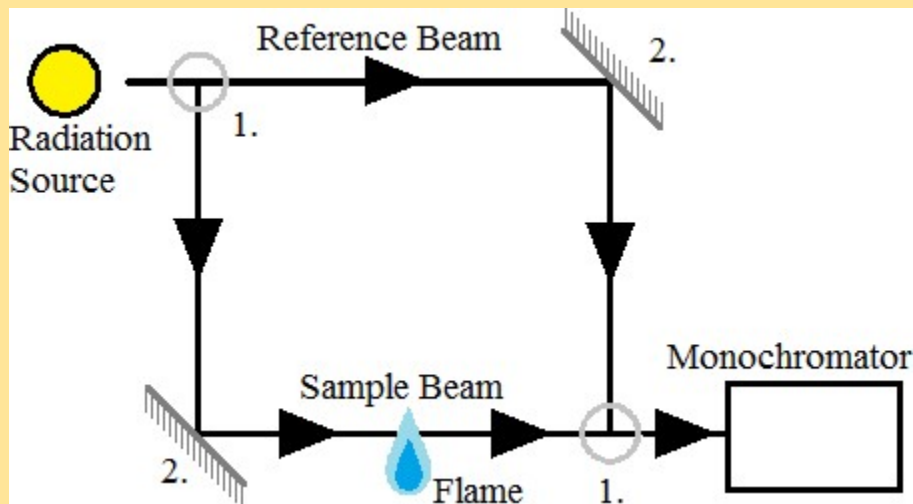

Figure 1.4.12: A schematic of a double-beam spectrometer showing the 50/50 beam splitters (1) and the mirrors (2).

Obtaining Measurements

Sample preparation

Sample preparation is extremely varied because of the range of samples that can be analyzed. Regardless of the type of sample, certain considerations should be made. These include the laboratory environment, the vessel holding the sample, storage of the sample, and pretreatment of the sample.

Sample preparation begins with having a clean environment to work in. AAS is often used to measure trace elements, in which case contamination can lead to severe error. Possible equipment includes laminar flow hoods, clean rooms, and closed, clean vessels for transportation of the sample. Not only must the sample be kept clean, it also needs to be conserved in terms of pH, constituents, and any other properties that could alter the contents.

When trace elements are stored, the material of the vessel walls can adsorb some of the analyte leading to poor results. To correct for this, perfluoroalkoxy polymers (PFA), silica, glassy carbon, and other materials with inert surfaces are often used as the storage material. Acidifying the solution with hydrochloric or nitric acid can also help prevent ions from adhering to the walls of the vessel by competing for the space. The vessels should also contain a minimal surface area in order to minimize possible adsorption sites.

Bright field microscopy

Bright field microscopy is the simplest of all the optical microscopy illumination techniques. Sample illumination is transmitted (i.e., illuminated from below and observed from above) white light and contrast in the sample is caused by absorbance of some of the transmitted light in dense areas of the sample. Bright field microscopy is the simplest of a range of techniques used for illumination of samples in light microscopes and its simplicity makes it a popular technique. The typical appearance of a bright field microscopy image is a dark sample on a bright background, hence the name.

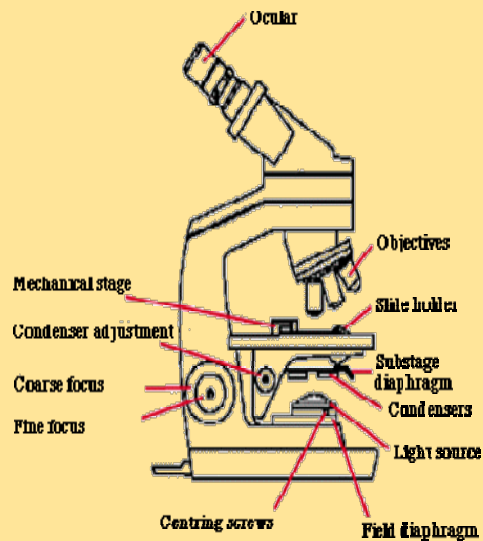
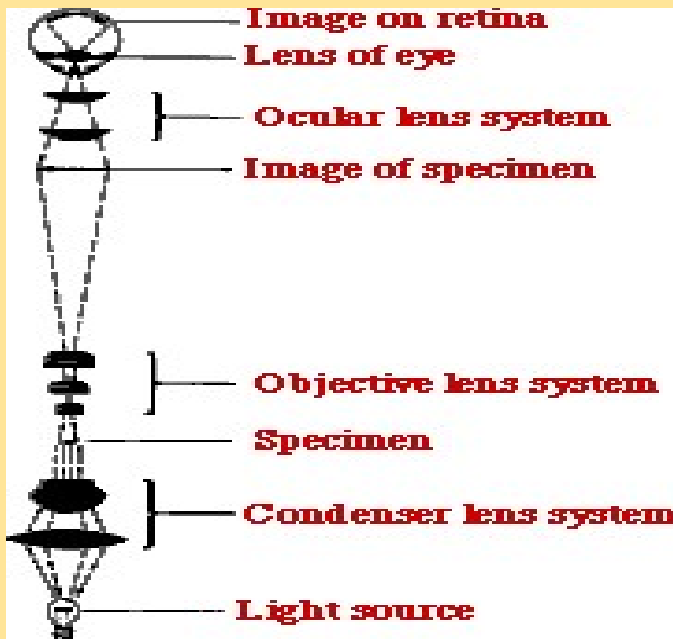

Light path

The light path of a bright field microscope is extremely simple, no additional components are required beyond the normal light microscope setup. The light path therefore consists of:

light source

1. a transillumination light source, commonly a halogen lamp in the microscope stand; A **halogen lamp**, also known as a **tungsten halogen lamp** or **quartz iodine lamp**, is an incandescent lamp that has a small amount of a halogen such as iodine or bromine added. The combination of the halogen gas and the tungsten filament produces a **halogen cycle** chemical reaction which redeposits evaporated tungsten back onto the filament, increasing its life and maintaining the clarity of the envelope
2. a **condenser lens** which focuses light from the light source onto the sample. A **condenser** is one of the main components of the optical system of many transmitted light compound microscopes. A condenser is a lens that serves to concentrate light from the illumination source that is in turn focused through the object and magnified by the objective lens.
3. **objective lens** : In an optical instrument, the **objective** is the optical element that gathers light from the object being observed and focuses the light rays to produce a real image.

Objectives can be single lenses or mirrors, or combinations of several optical elements. Microscope objectives are characterized by two parameters: magnification and numerical aperture. The typically ranges are 4× , 10x , 40x and 100×.

4. **oculars** to view the sample image. An **eyepiece**, or **ocular lens**, is a type of lens that is attached to a variety of optical devices such as microscopes. It is so named because it is usually the lens that is closest to the eye when someone looks through the device. The objective lens or mirror collects light and brings it to focus creating an image. The eyepiece is placed near the focal point of the objective to magnify this image. The amount of magnification depends on the focal length of the eyepiece.

Magnification is the process of enlarging something only in appearance, not in physical size. Typically magnification is related to scaling up visuals or images to be able to see more detail, increasing resolution.

Resolving power is the ability of an imaging device to separate (i.e., to see as distinct) points of an object that are located at a small angular distance..

In optics, the **numerical aperture (NA)** of an optical system is a dimensionless number that characterizes the range of angles over which the system can accept or emit light. In most areas of optics, and especially in microscopy, the numerical aperture of an optical system such as an objective lens is defined by

$$NA = n \sin \theta$$

where n is the index of refraction of the medium in which the lens is working (1.0 for air, 1.33 for pure water, and up to 1.56 for oils; see also list of refractive indices), and θ is the half-angle of the maximum cone of light that can enter or exit the lens. In general, this is the angle of the real marginal ray in the system

Working Performance

Bright field microscopy typically has low contrast with most biological samples as few absorb light to a great extent. Staining is often required to increase contrast, which prevents use on live cells in many situations. Bright field illumination is useful for samples which have an intrinsic colour, for example chloroplasts in plant cells.

Light is first emitted by the light **source** and is directed by the **condenser lens** on to the specimen, which might be a loose object, a prepared plate or almost anything. A microscope can even be applied to small parts of larger objects, though with a bit more difficulty. (The light does not absolutely need to originate below the specimen.)

The light from the specimen then passes through the objective lens. This lens is often selected from among three or four and is the main determinant for the level of magnification. It bends the light rays and in the case of this example sends them to a **projector lens**, which reverses their direction so that when the image reaches the eye it will not appear "upside-down". Not all

microscopes have a projector lens, so the viewer may be seeing a reverse image. In these cases, when the slide is moved, it will appear to be moving in the opposite direction to the viewer.

The light rays then travel to the **ocular lens** or "eye piece". This is often a 10X magnification lens, meaning it magnifies the magnified image an additional ten times. The image is then projected into the eye. It is very seldom that a specimen is in focus the moment it is placed beneath a microscope. This means that some adjustment will have to be made. Unlike in telescopes, the focal length between lenses remains constant when adjusting the focus. The lens apparatus is brought closer to or further from the object. The focus adjustment is often along the neck of the tube containing the lenses, but it might just as well move the slide up and down. The best way to make this adjustment is to make a course adjustment so that it is too close to the object and then back off with the fine adjustment². This helps to ensure that the specimen is not inadvertently smashed by the lens.

Advantages

The name "brightfield" is derived from the fact that the specimen is dark and contrasted by the surrounding bright viewing field. Simple light microscopes are sometimes referred to as bright field microscopes.

Brightfield microscopy is very simple to use with fewer adjustments needed to be made to view specimens.

Some specimens can be viewed without staining and the optics used in the brightfield technique don't alter the color of the specimen.

It is adaptable with new technology and optional pieces of equipment can be implemented with brightfield illumination to give versatility in the tasks it can perform.

Disadvantages

Certain disadvantages are inherent in any optical imaging technique.

- By using an aperture diaphragm for contrast, past a certain point, greater contrast adds distortion. However, employing an iris diaphragm will help compensate for this problem.
- Brightfield microscopy can't be used to observe living specimens of bacteria, although when using fixed specimens, bacteria have an optimum viewing magnification of 1000x.

Brightfield microscopy has very low contrast and most cells absolutely have to be stained to be seen; staining may introduce extraneous details into the specimen that should not be present.

Also, the user will need to be knowledgeable in proper staining techniques.

Lastly, this method requires a strong light source for high magnification applications and intense lighting can produce heat that will damage specimens or kill living microorganisms.

Dark field microscopy

Dark field microscopy (dark ground microscopy) describes microscopy methods, in both light and electron microscopy, which exclude the unscattered beam from the image. As a result, the field around the specimen (i.e. where there is no specimen to scatter the beam) is generally dark.

In optical microscopy, darkfield describes an illumination technique used to enhance the contrast in unstained samples. It works by illuminating the sample with light that will not be collected by the objective lens, and thus will not form part of the image. This produces the classic appearance of a dark, almost black, background with bright objects on it.

The light's path

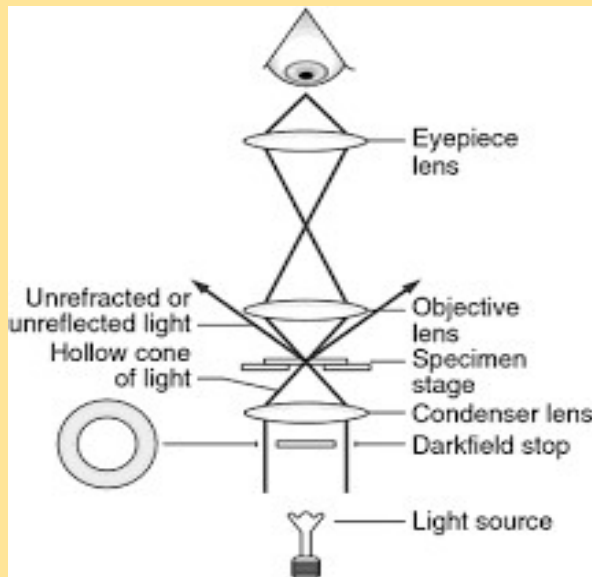
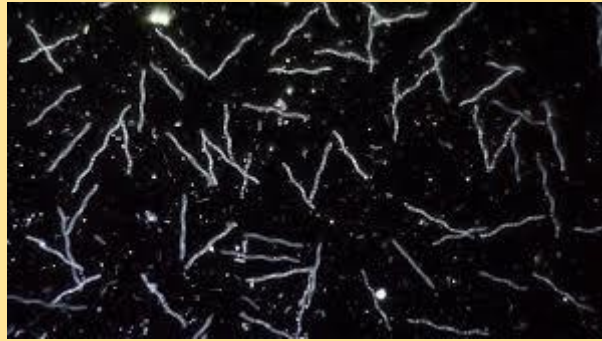

Diagram illustrating the light path through a dark field microscope.

1. Light enters the microscope for illumination of the sample.
2. A specially sized disc, the *patch stop* (see figure) blocks some light from the light source, leaving an outer ring of illumination. A wide phase annulus can also be reasonably substituted at low magnification.
3. The condenser lens focuses the light towards the sample.
4. The light enters the sample. Most is directly transmitted, while some is scattered from the sample.
5. The **scattered light** enters the objective lens, while the **directly transmitted light** simply misses the lens and is not collected due to a *direct illumination block* (see figure).
6. Only the scattered light goes on to produce the image, while the directly transmitted light is omitted.



Dark field microscopy produces an image with a dark background.

Advantages and disadvantages

Dark field microscopy is a very simple yet effective technique and well suited for uses involving live and unstained biological samples, such as a smear from a tissue culture or individual water-borne single-celled organisms. Considering the simplicity of the setup, the quality of images obtained from this technique is impressive.

The main limitation of dark field microscopy is the low light levels seen in the final image. This means the sample must be very strongly illuminated, which can cause damage to the sample. Dark field microscopy techniques are almost entirely free of artifacts, due to the nature of the process. However the interpretation of dark field images must be done with great care as common dark features of bright field microscopy images may be invisible, and vice versa.

While the dark field image may first appear to be a negative of the bright field image, different effects are visible in each. In bright field microscopy, features are visible where either a shadow is cast on the surface by the incident light, or a part of the surface is less reflective, possibly by the presence of pits or scratches. Raised features that are too smooth to cast shadows will not appear in bright field images, but the light that reflects off the sides of the feature will be visible in the dark field images.

Fluorescence microscope

A **fluorescence microscope** is an optical microscope that uses fluorescence and phosphorescence instead of, or in addition to, reflection and absorption to study properties of organic or inorganic substances.^{[1][2]} The "fluorescence microscope" refers to any microscope that uses fluorescence to generate an image, whether it is a more simple set up like an epifluorescence microscope, or a more complicated design such as a confocal microscope, which uses optical sectioning to get better resolution of the fluorescent image.

Principle

The specimen is illuminated with light of a specific wavelength (or wavelengths) which is absorbed by the fluorophores, causing them to emit light of longer wavelengths (i.e., of a different color than the absorbed light). The illumination light is separated from the much weaker emitted fluorescence through the use of a spectral emission filter. Typical components of a fluorescence microscope are a light source (xenon arc lamp or mercury-vapor lamp are common; more advanced forms are high-power LEDs and lasers), the excitation filter, the dichroic mirror (or dichroic beamsplitter), and the emission filter (see figure below). The filters and the dichroic are chosen to match the spectral excitation and emission characteristics of the fluorophore used to label the specimen.^[1] In this manner, the distribution of a single fluorophore (color) is imaged at a time. Multi-color images of several types of fluorophores must be composed by combining several single-color images.^[1]

Most fluorescence microscopes in use are epifluorescence microscopes, where excitation of the fluorophore and detection of the fluorescence are done through the same light path (i.e. through the objective). These microscopes are widely used in biology and are the basis for more advanced microscope designs, such as the confocal microscope and the total internal reflection fluorescence microscope (TIRF).

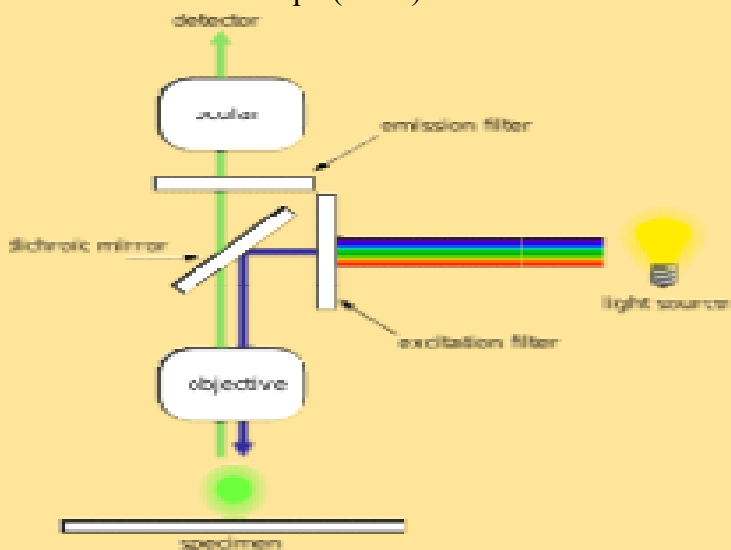

Schematic of a fluorescence microscope.

The majority of fluorescence microscopes, especially those used in the life sciences, are of the epifluorescence design shown in the diagram. Light of the excitation wavelength is focused on the specimen through the objective lens. The fluorescence emitted by the specimen is focused to the detector by the same objective that is used for the excitation which for greatest sensitivity will have a very high numerical aperture. Since most of the excitation light is transmitted through the specimen, only reflected excitatory light reaches the objective together with the emitted light and the epifluorescence method therefore gives a high signal to noise ratio. An additional barrier filter between the objective and the detector can filter out the remaining excitation light from fluorescent light.

Light sources

Fluorescence microscopy requires intense, near-monochromatic, illumination which some widespread light sources, like halogen lamps cannot provide. Four main types of light source are used, including xenon arc lamps or mercury-vapor lamps with an excitation filter, lasers, supercontinuum sources, and high-power LEDs. Lasers are most widely used for more complex fluorescence microscopy techniques like confocal microscopy and total internal reflection fluorescence microscopy while xenon lamps, and mercury lamps, and LEDs with a dichroic excitation filter are commonly used for widefield epifluorescence microscopes.

Sample preparation



A sample of herring sperm stained with SYBR green in a cuvette illuminated by blue light in an epifluorescence microscope. The SYBR green in the sample binds to the herring sperm DNA and, once bound, fluoresces giving off green light when illuminated by blue light.

In order for a sample to be suitable for fluorescence microscopy it must be fluorescent. There are several methods of creating a fluorescent sample; the main techniques are labelling with fluorescent stains or, in the case of biological samples, expression of a fluorescent protein. Alternatively the intrinsic fluorescence of a

sample (i.e., autofluorescence) can be used.^[1] In the life sciences fluorescence microscopy is a powerful tool which allows the specific and sensitive staining of a specimen in order to detect the distribution of proteins or other molecules of interest. As a result there is a diverse range of techniques for fluorescent staining of biological samples.

Biological fluorescent stains

Many fluorescent stains have been designed for a range of biological molecules. Some of these are small molecules which are intrinsically fluorescent and bind a biological molecule of interest. Major examples of these are nucleic acid stains like DAPI and Hoechst (excited by UV wavelength light) and DRAQ5 and DRAQ7 (optimally excited by red light) which all bind the minor groove of DNA, thus labelling the nuclei of cells. Others are drugs or toxins which bind specific cellular structures and have been derivatised with a fluorescent reporter. A major example of this class of fluorescent stain is phalloidin which is used to stain actin fibres in mammalian cells.

There are many fluorescent molecules called fluorophores or fluorochromes such as fluorescein, Alexa Fluors or DyLight 488, which can be chemically linked to a different molecule which binds the target of interest within the sample.

Advantages of Fluorescence Microscope

It helps to identify the specific molecules with the help of the fluorescence substances. Tracing the location of a specific protein in the specimen.

Also for visualizing or capturing the standard pattern how the fluorescent substances affect the cellular structure or tissues at different stages like a **heating stage**.

It offers a magnified and clear image of the cellular molecules in the specimen as compared to the traditional optical microscope.

Disadvantages

The greatest disadvantage in fluorescent microscopy is the photobleaching and you cannot focus your specimen for much time at higher magnification (as intense light is required) for more time. And also it needs a quite a sophisticated instrumentation as well as lots of experimental optimization.

Fluorophores lose their ability to fluoresce as they are illuminated in a process called photobleaching. Photobleaching occurs as the fluorescent molecules accumulate chemical damage from the electrons excited during fluorescence. Photobleaching can severely limit the time over which a sample can be observed by fluorescent microscopy. Several techniques exist to reduce photobleaching such as the use of more robust fluorophores, by minimizing illumination, or by using photoprotective scavenger chemicals.

Fluorescence microscopy with fluorescent reporter proteins has enabled analysis of live cells by fluorescence microscopy, however cells are susceptible to phototoxicity, particularly with short wavelength light. Furthermore, fluorescent molecules have a tendency to generate reactive chemical species when under illumination which enhances the phototoxic effect.

Phase contrast microscopy

Phase contrast microscopy is an optical microscopy technique that converts phase shifts in light passing through a transparent specimen to brightness changes in the image. Phase shifts themselves are invisible, but become visible when shown as brightness variations.

When light waves travel through a medium other than vacuum, interaction with the medium causes the wave amplitude and phase to change in a manner dependent on properties of the medium. Changes in amplitude (brightness) arise from the scattering and absorption of light, which is often wavelength dependent and may give rise to colors. Photographic equipment and the human eye are only sensitive to amplitude variations. Without special arrangements, phase changes are therefore invisible. Yet, often these changes in phase carry important information.

History and Background Information

Frits Zernike, a Dutch physicist and mathematician, built the first phase contrast microscope in 1938.

It took some time before the scientific community recognized the potential of Zernike's discovery; he won the Nobel Prize in 1953 and the German-based company Zeiss began manufacturing his phase contrast microscope during World War II.

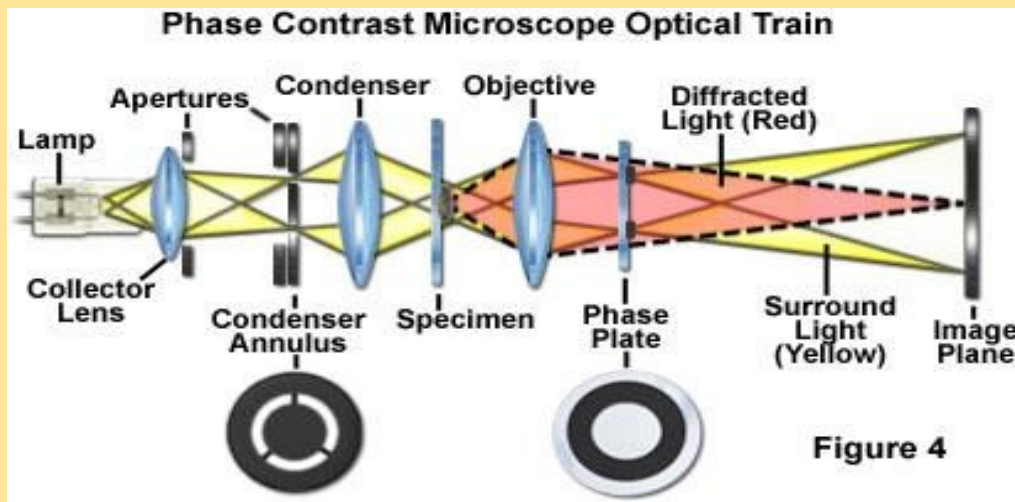

Working principle

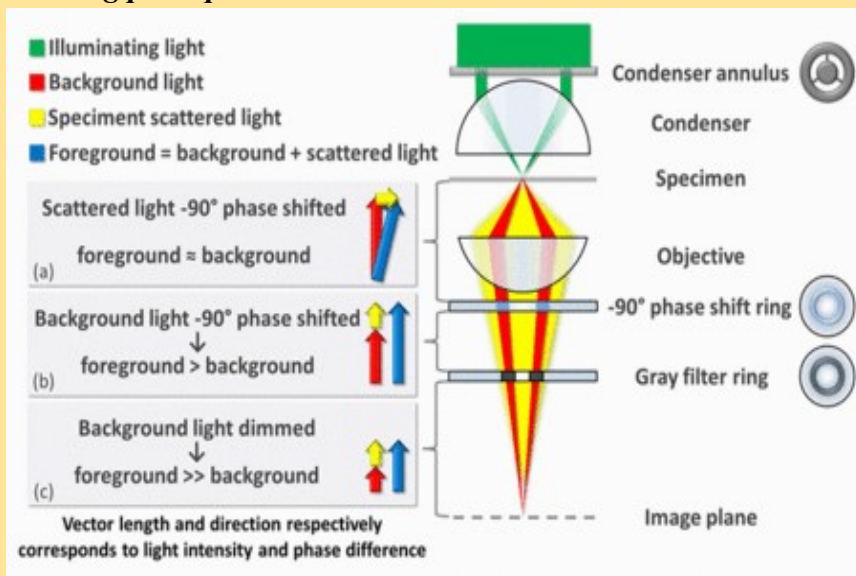

The basic principle to make phase changes visible in phase contrast microscopy is to separate the illuminating background light from the specimen scattered light, which make up the foreground details, and to manipulate these differently.

The ring shaped illuminating light (green) that passes the condenser annulus is focused on the specimen by the condenser. Some of the illuminating light is scattered by the specimen (yellow). The remaining light is unaffected by the specimen and form the background light (red). When observing unstained biological specimen, the scattered light is weak and typically phase shifted by -90° — relative to the background light. This leads to that the foreground (blue vector) and the background (red vector) nearly have the same intensity, resulting in a low image contrast (a).

In a phase contrast microscope, the image contrast is improved in two steps. The background light is phase shifted -90° by passing it through a phase shift ring. This eliminates the phase difference between the background and the scattered light, leading to an increased intensity difference between foreground and background (b). To further increase contrast, the background is dimmed by a gray filter ring (c). Some of the scattered light will be phase shifted and dimmed by the rings. However, the background light is affected to a much greater extent, which creates the phase contrast effect.

The above describes *negative phase contrast*. In its *positive* form, the background light is instead phase shifted by $+90^\circ$. The background light will thus be 180° out of phase relative to the scattered light. This results in that the scattered light will be subtracted from the background light in (b) to form an image where the foreground is darker than the background.

Advantages

The advantages of the phase contrast microscope include:

- The capacity to observe living cells and, as such, the ability to examine cells in a natural state
- Observing a living organism in its natural state and/or environment can provide far more information than specimens that need to be killed, fixed or stain to view under a microscope
- High-contrast, high-resolution images
- Ideal for studying and interpreting thin specimens
- Ability to combine with other means of observation, such as fluorescence
- Modern phase contrast microscopes, with CCD or CMOS computer devices, can capture photo and/or video images

In addition, advances to the phase contrast microscope, especially those that incorporate technology, enable a scientist to hone in on minute internal structures of a particle and can even detect a mere small number of protein molecules.

Disadvantages

Disadvantages and limitations of phase contrast:

- Annuli or rings limit the aperture to some extent, which decreases resolution
- This method of observation is not ideal for thick organisms or particles
- Thick specimens can appear distorted
- Images may appear grey or green, if white or green lights are used, respectively, resulting in poor photomicrography
- Shade-off and halo effect, referred to as phase artifacts
- Shade-off occurs with larger particles, results in a steady reduction of contrast moving from the center of the object toward its edges
- Halo effect, where images are often surrounded by bright areas, which obscure details along the perimeter of the specimen.

Confocal microscopy

- Later developments in science including development of computers and laser technology and digital manipulations of images using algorithms, grew the advances in confocal microscopy, forming practically usable confocal microscopes by a series of scientists including G. Fred Brakenhoff (1979), Colin Sheppard, Tony Wilson, Brad Amos, and John White (1980s).
- The first commercial confocal microscope was developed in 1987 with improved optics and electronics, powerful lasers with high scanning efficiency.
- The modern confocal Microscope has all the possible integration of technology and mechanical components including optical components, which perform the primary function of the configuration by use of electronic detectors, a computer and laser systems.
- The functioning of the confocal microscope is a collective role of all its components to produce an electronic image. To date, these microscopes have been used to investigate molecules, microbial cells, and tissues.

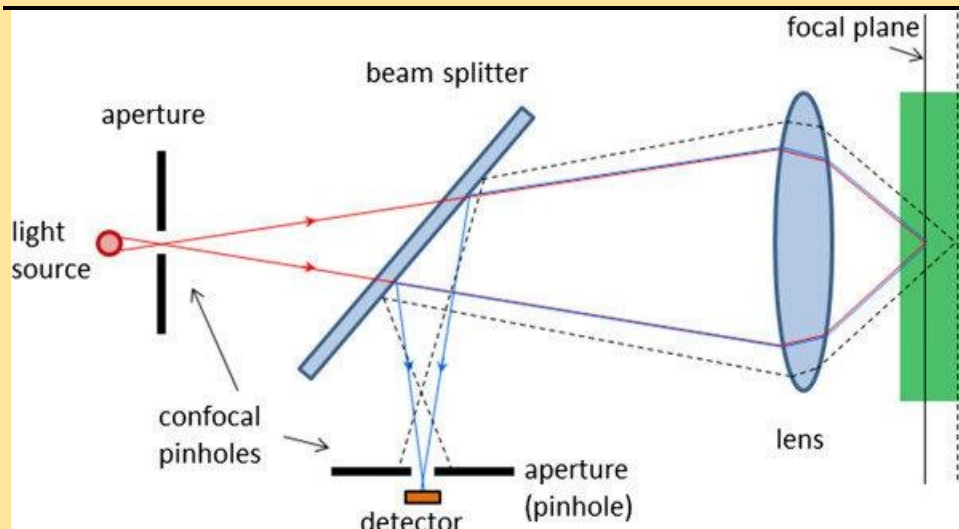

Principle of the Confocal Microscope

- Normally a conventional (wide-field) Microscope uses different wavelengths from a light source, to visualize and illuminate a large area of a specimen, forming fuzzy, murky and crowded images, because cell sample images are captured from all directions, without a focal point.
- To avoid these issues, a Confocal Microscope is used. In wide-field or Fluorescent microscopes, the whole specimen receives light, receiving complete excitement and emitting light which is detected by a photodetector on the microscope. However, with the confocal microscope, point illumination is the principle working mechanism.
- A specimen is stained with fluorochrome is examined. When a beam of light is focused at a particular point of the fluoro-chromatic specimen, it produces an illumination that is focused by the objective lens to a plane above the objectives. The objective has an aperture on the focal plane located above it, which primarily functions to block any stray light from reaching the specimen.
- A measure of the illumination point is about 0.25 to 0.8 μm in diameter, determined by the objective numerical aperture and 0.5 to 1.5 μm deep, with the brightest intensity.
- The specimen normally lies between the camera lens and the perfect point of focus, known as the **plane of focus**. Using the laser from the microscope, the laser scans over a plane on the specimen (beam scanning) or by moving the stage (stage scanning). A detector then will measure the illumination producing an image of the optical section. scanning several optical sections, they are collected in a computerized system as data, forming a 3D image. The image can be measured and quantified.
- Its outcome is also favored by the aperture found above the objective which blocks stray light.
- Images produced by the confocal microscope has a very good contrast and resolution capacity despite the thickness of the specimen. Images are stored in the high-resolution 3D image of the cell complexes including its structures.
- The main characteristic of the Confocal Microscope is that it only detects what is focused and anything outside the focus point, appears black.

The image of the specimen is formed when the microscope scanner, scans the focused beam across a selected area with the control of two high-speed oscillating mirrors. Their movement is facilitated by galvanometer motors. One mirror moves the beam from left to right on the lateral **X-axis** while the second mirror translates the beam along the **Y-axis**. After a scan on the X-axis, the beam moves rapidly back to the starting point to start a new scan, a process known as flyback. No information is collected during the flyback process, therefore the point of focus, which is the area of interest is what is illuminated by the laser scanner.

Parts of the Confocal Microscope

The Confocal Laser Scanning Microscope is made up a few components:

1. Objective lens
2. Out-of-focus plane
3. In-focus plane
4. Beam splitters
5. Detector
6. Confocal pinhole (aperture)
7. Laser
8. Oscillator Mirrors

-
1. **Confocal laser scanning Microscope** – It uses several mirrors that scan along the X
-

and Y axes on the specimen, by scanning and descanning, and the image passes through a pinhole into the detector.

2. **Spinning disk**, also known as the Nipkow disk, is a type of confocal microscope that uses several movable apertures (pinholes) on a disc to scan for spots of light in a parallel manner over a specified plane, over a long period. The longer the time the less the excitation energy required for illumination, as compared to the Confocal laser scanning microscope. Lessened excitation energy reduces phototoxicity and photobleaching, hence its mainly used to imaging live cells.
3. **Dual spinning Disk** or Microlens enhanced confocal Microscope -, it was invented by Yokogawa electric; it works similarly to the spinning disk, the only difference is, it has a second spinning-disk with micro-lenses that is found before the spinning disk that contains the pinholes. The micro-lenses capture broadband of light focusing it into each pinhole, thus increasing the amount of light that is directed into each pinhole, reducing the amount of light that is blocked by the spinning disk. This Confocal Microscopes with enhanced Microlenses are much more sensitive than the spinning disks.
4. **Programmable array Microscope (PAM)** – this type of confocal microscope uses a spatial light modulator (SLM – an object that imposes some form of spatially-varying modulation on a beam of light). The SLM has a set of movable apertures (pinholes), with arrays of pixels of opacity, reflectivity or optical rotation. The SLM also has microelectrochemical mirrors that capture the image by a charge-coupled device (CCD) camera.

Each of the confocal microscopes has its advantages and disadvantages, but they all capture the images by recording the images and sometimes they can be programmed to get high-density images, especially the Programmed array Microscope and the Spinning disk confocal

Microscope.

Applications of the Confocal Microscope

The Confocal Microscope is used in a wide range of fields including Biomedical sciences, Cells Biology, genetics, Microbiology, Developmental Biology, Spectroscopy, Nanoscience (nanoimaging) and Quantum Optics.

1. In Biomedical sciences, it is used in the analysis of eye corneal infections, by quantifying and qualitatively analyzing the endothelial cells of the cornea.
 2. Used to identify the presence of fungal elements in the corneal stroma, during keratomycosis infection, or rapid diagnosis and quick therapeutic response.
 3. It is used in pharmaceutical industries, to ensure the maintenance of thin-film pharmaceuticals, allowing control of the quality and uniformity of drug distribution.
 4. It is used to retrieve data from some 3D optical storage systems. This has helped in quantifying the age of Magdalen papyrus.
-

Advantages

1. The advantage of the Confocal microscope is that it improves the outcome of the image because it analyses the image from one optical point to another, therefore there is no interference with scattered light from other parts of the specimen.
 2. They have better resolution and each point of interest is visualized and captured.
 3. It can be used to study live and fixed cells
 4. It can be used to collect serial optical sections.
 5. It illuminates uniformly across the focus points.
 6. The adjust their magnification electronically, without changing the objectives, by a factor known as the zoom factor.
 7. It generates 3D sets of images. Limitations
 1. They have a limited number of excitation wavelengths, with very narrow bands.
 2. They are expensive to produce the ultraviolet rays used by the Confocal Microscopes
 3. They are also expensive to manufacture and to purchase.
-

Electron microscope

An **electron microscope** is a microscope that uses a beam of accelerated electrons as a source of illumination. As the wavelength of an electron can be up to 100,000 times shorter than that of visible light photons, electron microscopes have a higher resolving power than light microscopes and can reveal the structure of smaller objects. A transmission electron microscope can achieve better than 50 pm resolution^[1] and magnifications of up to about 10,000,000x whereas most light microscopes are limited by diffraction to about 200 nm resolution and useful magnifications below 2000x. Transmission electron microscopes use electrostatic and electromagnetic lenses to

control the electron beam and focus it to form an image. These electron optical lenses are analogous to the glass lenses of an optical light microscope. Electron microscopes are used to investigate the ultrastructure of a wide range of biological and inorganic specimens including microorganisms, cells, large molecules, biopsy samples, metals, and crystals. Industrially, electron microscopes are often used for quality control and failure analysis. Modern electron microscopes produce electron micrographs using specialized digital cameras and frame grabbers to capture the image.

Transmission electron microscope (TEM)

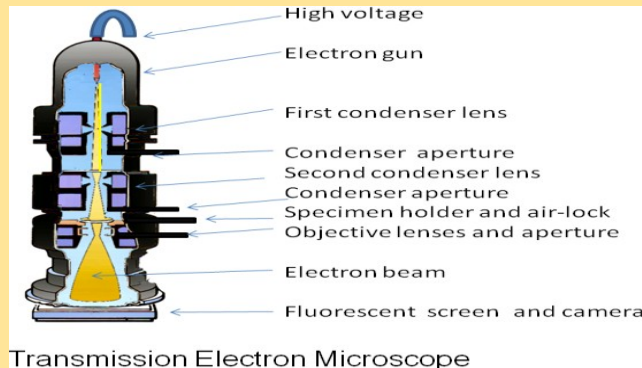

The original form of electron microscope, the transmission electron microscope (TEM) uses a high voltage electron beam to illuminate the specimen and create an image. The electron beam is produced by an **electron gun**, commonly fitted with a tungsten filament cathode as the electron source. The electron beam is accelerated by an anode typically at +100 keV (40 to 400 keV) with respect to the cathode, focused by **electrostatic and electromagnetic lenses**, and transmitted through the specimen that is in part transparent to electrons and in part scatters them out of the beam. When it emerges from the specimen, the electron beam carries information about the structure of the specimen that is magnified by the objective lens system of the microscope. The spatial variation in this information (the "image") may be viewed by projecting the magnified electron image onto a fluorescent viewing screen coated with a phosphor or **scintillator material** such as zinc sulfide. Alternatively, the image can be photographically recorded by exposing a photographic film or plate directly to the electron beam, or a high-resolution phosphor may be coupled by means of a lens optical system or a fibre optic light-guide to the sensor of a digital camera. The image detected by the digital camera may be displayed on a monitor or computer.

The resolution of TEMs is limited primarily by spherical aberration, but a new generation of aberration correctors have been able to partially overcome spherical aberration to increase resolution. Hardware correction of spherical aberration for the high-resolution transmission electron microscopy (HRTEM) has allowed the production of images with resolution below 0.5 angstrom (50 picometres)^[1] and magnifications above 50 million times.^[10] The ability to determine the positions of atoms within materials has made the HRTEM an important tool for nano-technologies research and development.

Advantages

Transmission electron microscopes are often used in electron diffraction mode. The advantages of electron diffraction over X-ray crystallography are that the specimen need not be a single crystal or even a polycrystalline powder, and also that the Fourier transform reconstruction of the object's magnified structure occurs physically and thus avoids the need for solving the phase problem faced by the X-ray crystallographers after obtaining their X-ray diffraction patterns of a single crystal or polycrystalline powder.

Disadvantages

The major disadvantage of the transmission electron microscope is the need for extremely thin sections of the specimens, typically about 100 nanometers. Biological specimens are typically required to be chemically fixed, dehydrated and embedded in a polymer resin to stabilize them sufficiently to allow ultrathin sectioning. Sections of biological specimens, organic polymers and similar materials may require special treatment with heavy atom labels in order to achieve the required image contrast.

Scanning electron microscope (SEM)

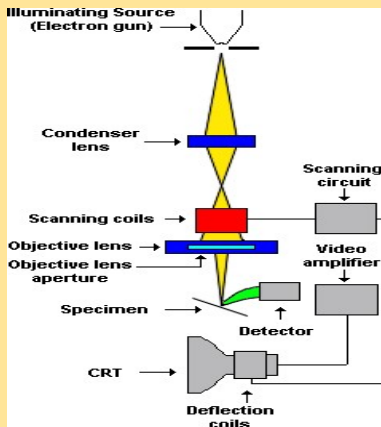

The SEM produces images by probing the specimen with a focused electron beam that is scanned across a rectangular area of the specimen (raster scanning). When the electron beam interacts with the specimen, it loses energy by a variety of mechanisms. The lost energy is converted into alternative forms such as heat, emission of low-energy secondary electrons and high-energy backscattered electrons, light emission (cathodoluminescence) or X-ray emission, all of which provide signals carrying information about the properties of the specimen surface, such as its topography and composition. The image displayed by an SEM maps the varying intensity of any of these signals into the image in a position corresponding to the position of the beam on the specimen when the signal was generated. In the SEM image of an ant shown below and to the right, the image was constructed from signals produced by a secondary electron detector, the normal or conventional imaging mode in most SEMs.

Generally, the image resolution of an SEM is at least an order of magnitude poorer than that of a TEM. However, because the SEM image relies on surface processes rather than transmission, it is able to image bulk samples up to many centimeters in size and (depending on instrument design and settings) has a great depth of field, and so can produce images that are good representations of the three-dimensional shape of the sample. Another advantage of SEM is its variety called

environmental scanning electron microscope (ESEM) can produce images of sufficient quality and resolution with the samples being wet or contained in low vacuum or gas. This greatly facilitates imaging biological samples that are unstable in the high vacuum of conventional electron microscopes.

Color

In their most common configurations, electron microscopes produce images with a single brightness value per pixel, with the results usually rendered in grayscale.^[12] However, often these images are then colorized through the use of feature-detection software, or simply by hand-editing using a graphics editor. This may be done to clarify structure or for aesthetic effect and generally does not add new information about the specimen.^[13]

Sample preparation

Materials to be viewed under an electron microscope may require processing to produce a suitable sample. The technique required varies depending on the specimen and the analysis required:

- *Chemical fixation* – for biological specimens aims to stabilize the specimen's mobile macromolecular structure by chemical crosslinking of proteins with aldehydes such as formaldehyde and glutaraldehyde, and lipids with osmium tetroxide.
- *Negative stain* – suspensions containing nanoparticles or fine biological material (such as viruses and bacteria) are briefly mixed with a dilute solution of an electron-opaque solution such as ammonium molybdate, uranyl acetate (or formate), or phosphotungstic acid. This mixture is applied to a suitably coated EM grid, blotted, then allowed to dry. Viewing of this preparation in the TEM should be carried out without delay for best results. The method is important in microbiology for fast but crude morphological identification, but can also be used as the basis for high resolution 3D reconstruction using EM tomography methodology when carbon films are used for support. Negative staining is also used for observation of nanoparticles.
- *Cryofixation* – freezing a specimen so rapidly, in liquid ethane, and maintained at liquid nitrogen or even liquid helium temperatures, so that the water forms vitreous (non-crystalline) ice. This preserves the specimen in a snapshot of its solution state. An entire field called cryo-electron microscopy has branched from this technique. With the development of cryo-electron microscopy of vitreous sections (CEMOVIS), it is now possible to observe samples from virtually any biological specimen close to its native state.^[citation needed]
- *Dehydration* – or replacement of water with organic solvents such as ethanol or acetone, followed by critical point drying or infiltration with embedding resins. Also freeze drying.
- *Embedding, biological specimens* – after dehydration, tissue for observation in the transmission electron microscope is embedded so it can be sectioned ready for viewing. To do this the tissue is passed through a 'transition solvent' such as propylene oxide (epoxypropane) or acetone and then infiltrated with an epoxy resin such as

Araldite, Epon, or Durcupan;^[18] tissues may also be embedded directly in water-miscible acrylic resin. After the resin has been polymerized (hardened) the sample is thin sectioned (ultrathin sections) and stained – it is then ready for viewing.

- *Embedding, materials* – after embedding in resin, the specimen is usually ground and polished to a mirror-like finish using ultra-fine abrasives. The polishing process must be performed carefully to minimize scratches and other polishing artifacts that reduce image quality.
- *Metal shadowing* – Metal (e.g. platinum) is evaporated from an overhead electrode and applied to the surface of a biological sample at an angle. The surface topography results in variations in the thickness of the metal that are seen as variations in brightness and contrast in the electron microscope image.
- *Replication* – A surface shadowed with metal (e.g. platinum, or a mixture of carbon and platinum) at an angle is coated with pure carbon evaporated from carbon electrodes at right angles to the surface. This is followed by removal of the specimen material (e.g. in an acid bath, using enzymes or by mechanical separation^[19]) to produce a surface replica that records the surface ultrastructure and can be examined using transmission electron microscopy.
- *Sectioning* – produces thin slices of specimen, semitransparent to electrons. These can be cut on an ultramicrotome with a diamond knife to produce ultra-thin sections about 60–90 nm thick. Disposable glass knives are also used because they can be made in the lab and are much cheaper.
- *Staining* – uses heavy metals such as lead, uranium or tungsten to scatter imaging electrons and thus give contrast between different structures, since many (especially biological) materials are nearly "transparent" to electrons (weak phase objects). In biology, specimens can be stained "en bloc" before embedding and also later after sectioning. Typically thin sections are stained for several minutes with an aqueous or alcoholic solution of uranyl acetate followed by aqueous lead citrate.^[20]
- *Freeze-fracture or freeze-etch* – a preparation method particularly useful for examining lipid membranes and their incorporated proteins in "face on" view. The fresh tissue or cell suspension is frozen rapidly (cryofixation), then fractured by breaking or by using a microtome while maintained at liquid nitrogen temperature. The cold fractured surface (sometimes "etched" by increasing the temperature to about –100 °C for several minutes to let some ice sublime) is then shadowed with evaporated platinum or gold at an average angle of 45° in a high vacuum evaporator. A second coat of carbon, evaporated perpendicular to the average surface plane is often performed to improve stability of the replica coating. The specimen is returned to room temperature and pressure, then the extremely fragile "pre-shadowed" metal replica of the fracture surface is released from the underlying biological material by careful chemical digestion with acids, hypochlorite solution or SDS detergent. The still-floating replica is thoroughly washed free from residual chemicals, carefully fished up on fine grids, dried then viewed in the TEM.
- *Ion beam milling* – thins samples until they are transparent to electrons by firing ions (typically argon) at the surface from an angle and sputtering material from the surface. A subclass of this is focused ion beam milling, where gallium ions are used to produce an electron transparent membrane in a specific region of the sample, for example

through a device within a microprocessor. Ion beam milling may also be used for cross-section polishing prior to SEM analysis of materials that are difficult to prepare using mechanical polishing.

- *Conductive coating* – an ultrathin coating of electrically conducting material, deposited either by high vacuum evaporation or by low vacuum sputter coating of the sample. This is done to prevent the accumulation of static electric fields at the specimen due to the electron irradiation required during imaging. The coating materials include gold, gold/palladium, platinum, tungsten, graphite, etc.
- *Earthing* – to avoid electrical charge accumulation on a conductive coated sample, it is usually electrically connected to the metal sample holder. Often an electrically conductive adhesive is used for this purpose.

Disadvantages

Electron microscopes are expensive to build and maintain, but the capital and running costs of confocal light microscope systems now overlaps with those of basic electron microscopes. Microscopes designed to achieve high resolutions must be housed in stable buildings (sometimes underground) with special services such as magnetic field cancelling systems.

The samples largely have to be viewed in vacuum, as the molecules that make up air would scatter the electrons. An exception is the environmental scanning electron microscope, which allows hydrated samples to be viewed in a low-pressure (up to 20 Torr or 2.7 kPa) and/or wet environment.

Scanning electron microscopes operating in conventional high-vacuum mode usually image conductive specimens; therefore non-conductive materials require conductive coating (gold/palladium alloy, carbon, osmium, etc.). The low-voltage mode of modern microscopes makes possible the observation of non-conductive specimens without coating. Non-conductive materials can be imaged also by a variable pressure (or environmental) scanning electron microscope.

Small, stable specimens such as carbon nanotubes, diatom frustules and small mineral crystals (asbestos fibres, for example) require no special treatment before being examined in the electron microscope. Samples of hydrated materials, including almost all biological specimens have to be prepared in various ways to stabilize them, reduce their thickness (ultrathin sectioning) and increase their electron optical contrast (staining).

Micrometry:

Micrometry is the science in which we have some measurement of the dimensions of an object being observed under the microscope. The method employs some special types of measuring devices which are so oriented that these can well be attached to or put into the microscope and observed. The object, to be measured, is calibrated against these scales.

Once we are observing an object under a microscope by the 5X objective and the 10X eyepiece we say that the image that we are able to perceive is $5 \times 10 = 50$ times of the object.

We get the magnified view no doubt and also that it is the perfect coordination of the dimensions, but to find out the exact size of the object will need precision and that is achieved through the application of some small scales called micrometers.

Types of Micrometry:

There are usually two types of micrometers, i.e. stage micrometer and ocular meter or ocular micrometer (Figs. 104, 105).

i. Stage Micrometer:

As is clear from its name it is for the measurement on the stage of the microscope where an object is to be kept. This micrometer is of a slide's shape and size and has a mount of very finely graduated scale. The scale measures only 1 mm and has a least count of 0.01 mm, i.e. 1 mm region is divided into 100 divisions. As 1 mm has 1000 μ , one division of stage micrometer is equivalent to 10 μ .

i. Ocular Meter:

This micrometer is used inside the eyepiece. The upper eye lens is unscrewed and the ocular meter is put into the tube of eyepiece, and the eye lens is again replaced in its original position. There are usually 50 or 100 divisions in the ocular meter which are engraved on the glass.

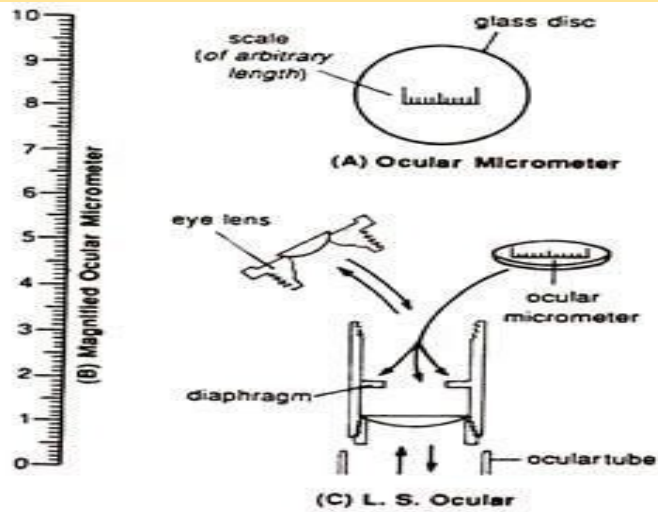

Fig. 104. A-C. A, An ocular micrometer; B, A magnified ocular micrometer scale; C, L.S. of ocular to show position of ocular micrometer in it.

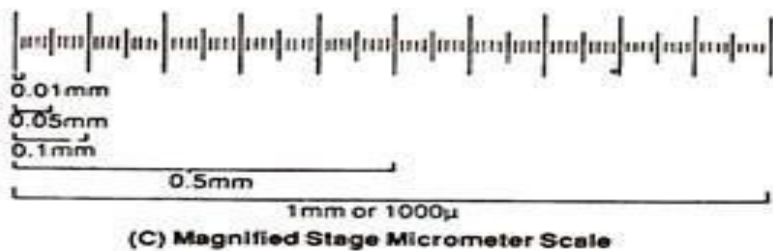
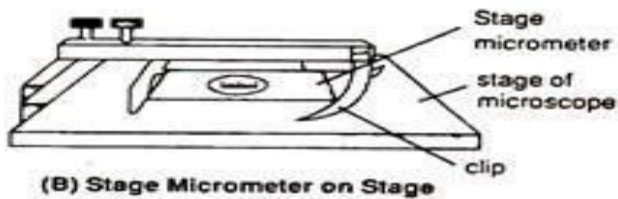
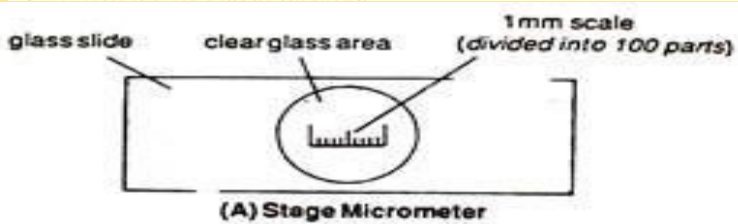

Fig. 105. A-C. A, A stage micrometer; B, Stage micrometer fixed on scale; C, Magnified stage micrometer scale.

Experiment No. 1:

Object:

To measure the dimensions of common microorganisms by calibration and standardization of microscope using stage micrometer and ocular micrometer.

Requirements:

Microscope, stage micrometer, ocular meter, slide of the microorganism to be measured.

Procedure:

To work out the measurements per ocular divisions the stage micrometer is kept under low power of microscope and is observed through the eyepiece having ocular meter. Suppose we have 10X objective and 5X eyepiece fitted in the microscope with a tube of 170 mm length.

At this magnification the number of ocular divisions coinciding the stage micrometer are observed (Fig. 106) and thence calculated for microns per ocular divisions, e.g., let us take that 5 ocular divisions coincide with 7 divisions of stage micrometer.

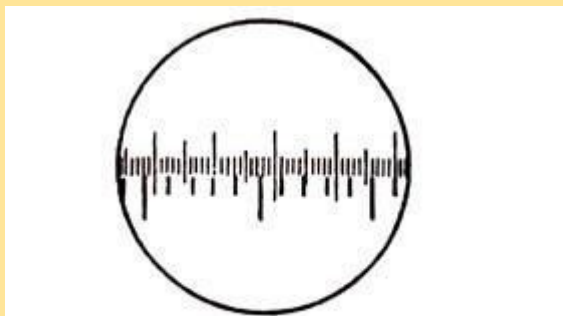

Fig. 106. Scales of stage and ocular micrometers superimposed.

Therefore, 5 ocular divisions = 7 stage micrometer divisions, or 5 ocular divisions = 0.07 mm (since 1 division = 0.01 mm).

$$1 \text{ ocular division} = 0.07/5\text{mm} = 0.07 \times 1000/5\mu$$

$$= 70/5\mu = 14\mu$$

Or, it can also be calculated by following formula:

One division of ocular = Number of stage micrometer divisions/Number of ocular meter divisions

$$\times 10$$

In the case mentioned above it will be $= 7 \times 10/5\mu = 14\mu$.

In this way the microscope is calibrated for different combinations of eyepieces and objective lenses and is kept for record. It is to note that this calibration will be just only of the tried lenses on this particular microscope.

Take three readings in this way, and the mean value of these readings will be the actual value of one part of ocular meter.

Record your data in the following table:

Observations :

S. No.	Number of divisions of stage micrometer	Number of divisions of ocular meter	Value of one division of oculometer stage $= \frac{\text{stage}}{\text{ocular}} \times 10 \mu$	Mean/Result
1.	7	5	$= \frac{7}{5} \times 10 = 14\mu$	
2.				
3.				
4.				

Measurement of the Microorganisms:

When the microscope is calibrated, then the object or organism to be measured is kept on the stage of the microscope and is observed through the eyepiece with ocular. The object is measured in the particular magnification by ocular divisions and then is changed into microns by multiplying ocular divisions with calibrated value of one ocular division in that particular magnification.

Suppose the diameter of an object (Fig. 107) is observed to be equal to 6 divisions of ocular, so the diameter of this object in microns will be:

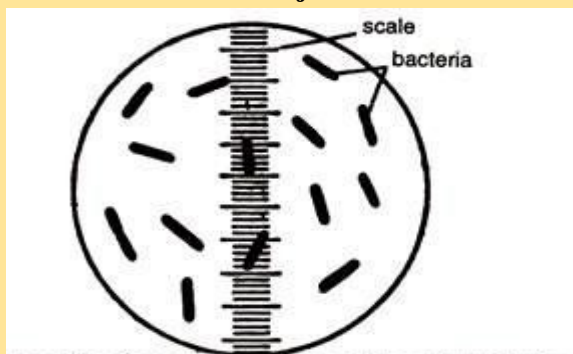

Fig. 107. Diagram showing an ocular micrometer for measuring the dimensions of bacterial cells.

$$6 \times 14\mu = 84\mu$$

In this way the object is measured in different magnifications.

Autoclave

The autoclave is a sealed device (similar to a pressure cooker) that kills microorganisms using **saturated steam under pressure**. The use of moist heat facilitates the killing of all microorganisms, including **heat-resistant endospores** which is achieved by heating the materials inside the device at temperatures above the boiling point of water. According to the principle of gas laws, this can be achieved by raising the **pressure inside the device**.

The boiling point (vapor pressure equals that of the surrounding atmosphere) of water varies depending upon the surrounding environmental pressure. For example, water boils at 100 °C at sea level (higher pressure), but at 93.4 °C at 1,905 metres altitude (lower pressure). So, in an enclosed device, if we raise the pressure, the temperature at which water boils also increases.

The usual procedure is to heat at 1.1 kilograms/square centimeter (kg/cm^2) [15 pounds/square inch (lb/in^2)] steam pressure, which yields a temperature of 121°C. At **121°C**, the time of autoclaving to achieve sterilization is generally considered to be **15-20 min**, depending on the volume of the load. To make sure, sterilization is successful one should ensure:

1. Air should be evacuated so that the chamber fills with steam.
2. Articles should be placed in the autoclave so that steam can easily penetrate them.

Note that it is not the pressure of the autoclave that kills the microorganisms but the high temperature that can be achieved when steam is placed under pressure.

If bulky objects are being sterilized, heat transfer to the interior will be slow, and the heating time must be sufficiently long so that the object is at 121°C for 15 min. Extended times are also required when large volumes of liquids are being autoclaved because large volumes take longer to reach sterilization temperature.

Components of Autoclave

Autoclave comprises of three parts: **a pressure chamber, a lid and an electrical heater**.

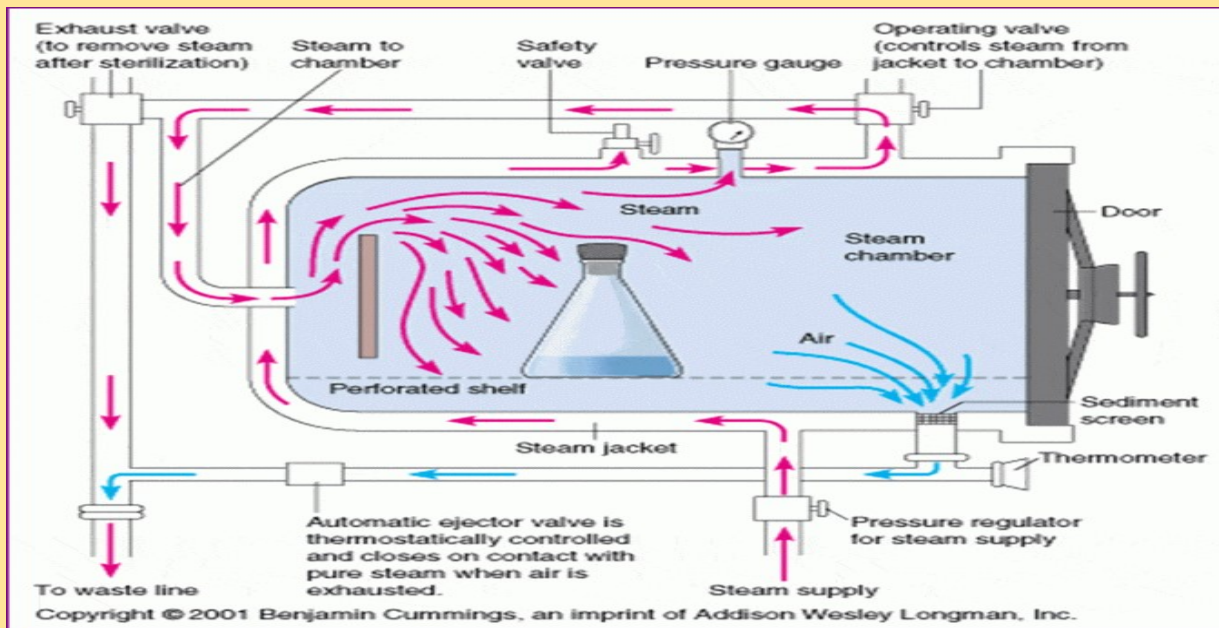

Gravity Displacement type Autoclave

Pressure chamber consists of –

- Large cylinder (vertical or horizontal) in which the materials to be sterilized are placed. It is made up of gunmetal or stainless steel and placed in a supporting iron case through
- A steam jacket (water compartment)

The lid is fastened by screw clamps and rendered airtight by an asbestos washer. The lid bears the following-

- A discharge tap for air and steam discharge
- A pressure gauge (sets the pressure at a particular level)
- A safety valve (to remove the excess steam)

An **electrical heater** is attached to the jacket; that heats the water to produce steam.

Types of Autoclaves

There are different types of autoclaves available.

1. Gravity displacement type autoclave: It is the most common type used in laboratories and is available in various sizes and dimensions.
 1. Vertical type (small volume capacity)
 2. Horizontal autoclave (large volume capacity)
2. Positive pressure displacement type autoclave
3. Negative pressure (vacuum) displacement type.

Procedure

- Place the material to be sterilized inside the pressure chamber and fill the cylinder with sufficient water
- Close the lid and put on the electrical heater.
- Adjust the safety valve to the required pressure.
- After the water boils, allow the steam and air mixture to escape through the discharge tap till all the air has been displaced
 - This can be tested by passing the steam-air mixture liberated from the discharge tap into a pail of water through a connecting rubber tube.
 - When the air bubbles stop coming in the pail, it indicates that all the air has been displaced by steam.
- Close the discharge tap. The steam pressure rises inside and when it reaches the desired set level (e.g. 15 pounds (lbs) per square inch in most cases), the safety valve opens and excess steam escapes out.
- Count the **holding period** from this point of time, which is about 15 minutes in most cases.
- After the holding period, stop the electrical heater and allow the autoclave to cool until the pressure gauge indicates that the pressure inside is equal to the atmospheric pressure.
- Open the discharge tap slowly and allow the air to enter the autoclave.
- Open the lid of the autoclave and remove the sterilized materials.

Sterilization control

Modern autoclaves have devices to maintain proper pressure and record internal temperature during operation. Regardless of the presence of such a device, autoclave pressure should be checked periodically and maintained.

Several methods are available to ensure that autoclaving achieve sterility. The effectiveness of the sterilization done by autoclave can be monitored by:

1. **Biological indicator:** Spores of *Geobacillus stearothermophilus* (formerly called *Bacillus stearothermophilus*) are the best indicator because they are resistant to steaming. Their spores are killed in 12 minutes at 121°C. The Centers for Disease Control (CDC) recommends weekly autoclaving of a culture containing heat resistant endospores of *Geobacillus stearothermophilus*, to check autoclave performance. The spore strip and an ampule of medium enclosed in a soft plastic vial are available commercially. The vial is placed in the center of the material to be sterilized and is autoclaved. Then the inner ampule is broken, releasing the medium, and the whole container is incubated. If no growth appears in the autoclaved culture, sterilization is deemed effective.
2. **Autoclave tapes:** Adhesive-backed paper tape with heat-sensitive, chemical indicator marking that change color or display-diagonal stripes, the words “sterile” or “autoclaved” when exposed to effective sterilization temperature (121°C) are used to check the efficacy of autoclaves.

These tapes are placed inside and near the center of large packages because heat penetration in those areas ensures proper heat penetration (For examples, when a large piece of meat is

roasted, the surface can be well done while the center may still remain unheated, and if the center is sufficiently heated then it means the desired temperature is achieved). Autoclave tapes are not fully reliable because they do not indicate how long appropriate conditions were maintained.

3. Other useful indicators are **thermocouple and Browne's tube**. **Thermocouple** is a temperature measuring device that records the temperature by a potentiometer. **Browne's tube** (invented by Albert Browne in 1930) contains a heat-sensitive red dye which turns green after being exposed to certain temperature for a definite period of time. Conversion of dye color gives information about the duration of time and temperature.

Uses of Autoclave

Autoclave is particularly useful for media containing water that cannot be sterilized by dry heat. It is the method of choice for sterilizing the following:

1. Surgical instruments
2. **Culture media**
3. Autoclavable plastic containers
4. Plastic tubes and pipette tips
5. Solutions and water
6. Biohazardous waste
7. Glassware (autoclave resistible)

Precautions

Never autoclave any liquid in a sealed container.

The following precautions should be taken while using an autoclave.

1. Autoclave should not be used for sterilizing waterproof materials, such as oil and grease or dry materials, such as glove powder
2. Materials are loaded in, such a way that it allows efficient steam penetration (do not overfill the chamber). It is more efficient and safer to run two separate, uncrowded loads than one crowded one.
3. Wrapping objects in aluminium foil is not recommended because it may interfere with steam penetration. Articles should be wrapped in materials that allow steam penetration.
4. Materials should not touch the sides or top of the chamber
5. The clean items and the wastes should be autoclaved separately.
6. Polyethylene trays should not be used as they may melt and cause damage to the autoclave.

Hot Air Oven

Hot Air Oven is commonly used for dry heat sterilization. Dry heat sterilization is a method of controlling microorganisms. It employs higher temperatures in the range of 160-180°C and requires exposures time up to 2 hour, depending upon the temperature employed.

The benefit of dry heat includes good penetrability and non-corrosive nature which makes it applicable for sterilizing glasswares and metal surgical instruments. It is also used for sterilizing non-aqueous thermostable liquids and thermostable powders.

Dry heat destroys bacterial endotoxins (or pyrogens) which are difficult to eliminate by other means and this property makes it applicable for sterilizing glass bottles which are to be filled aseptically). Dry heat kills by Oxidation, Protein Denaturation and toxic effects of elevated levels of electrolytes.

Hot Air Oven, which is usually used for the dry heat sterilization is consists of the following parts:

- An insulated chamber surrounded by an outer case containing electric heaters.
- A fan
- Shelves
- Thermocouples
- Temperature sensor
- Door locking controls

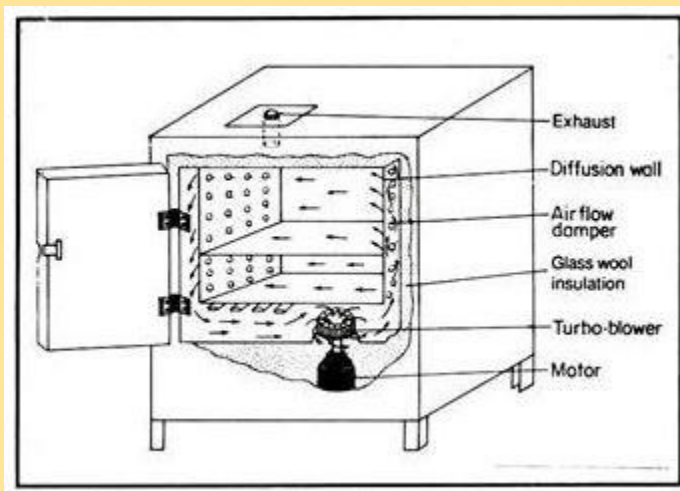

How to operate a Hot Air Oven?

- Articles to be sterilized are first wrapped or enclosed in containers of cardboard, paper or aluminum.
- Then, the materials are arranged to ensure uninterrupted air flow.
- Oven may be pre-heated for materials with poor heat conductivity.
- The temperature is allowed to fall to 40°C, prior to removal of sterilized material.

Advantages

- This treatment kills the bacterial endotoxin, not all treatments can do this.
- Protective of sharps or instruments with a cutting edge (fewer problems with dulling of cutting edges).
- Dry heat sterilization by Hot Air Oven does not leave any chemical residue.
- Eliminates “wet pack” problems in humid climates.

Disadvantages

- Plastic and rubber items cannot be dry-heat sterilized because temperatures used (160–170°C) are too high for these materials.
- Dry heat penetrates materials slowly and unevenly.
- And the Oven requires a continuous source of electricity.

Safety Guidelines

- Before placing in Hot Air Oven
 - i) Dry glasswares completely
 - ii) Plug test tubes with cotton wools
 - iii) Wrap glasswares in kraft papers. Do not overload the oven. Overloading alters heat convection and increases the time required to sterilize.
- Allow free circulation of air between the materials.
- The material used for wrapping instruments and other items must be porous enough to let steam through but tightly woven enough to protect against dust particles and microorganisms.

Incubator

Incubator, in microbiology, is an insulated and enclosed device that provides an optimal condition of temperature, humidity, and other environmental conditions required for the growth of organisms.

An incubator is a piece of vital laboratory equipment necessary for the cultivation of microorganisms under artificial conditions.

An incubator can be used for the cultivation of both unicellular and multicellular organisms.

Components/Parts of Incubator



A microbial incubator is made up of various units, some of which are:

Cabinet

- The cabinet is the main body of the incubator consisting of the double-walled cuboidal enclosure with a capacity ranging from 20 to 800L.
- The outer wall is made up of stainless steel sheets while the inner wall is made up of aluminum.
- The space between the two walls is filled with glass wool to provide insulation to the incubator.
- The insulation prevents heat loss and in turn, reduces the electric consumption, thereby ensuring the smooth working of the device.
- The inner wall of the incubator is provided with inward projections that support the shelves present inside the incubator.

Door

- A door is present in all incubators to close the insulated cabinet.
- The door also has insulation of its own. It is also provided with a glass that enables the visualization of the interior of the incubator during incubation without disturbing the interior environment.
- A handle is present on the outside of the door to help with the maneuvering of the door.

Control Panel

- On the outer wall of the incubator is a control panel with all the switches and indicators that allows the parameters of the incubator to be controlled.
- The control panel also has a switch to control the thermostat of the device.

Thermostat

- A thermostat is used to set the desired temperature of the incubator.
- After the desired temperature is reached, the thermostat automatically maintains the incubator at that temperature until the temperature is changed again.

Perforated shelves

- Bound to the inner wall are some perforated shelves onto which the plates with the culture media are placed.
- The perforations on the shelves allow the movement of hot air throughout the inside of the incubator.
- In some incubators, the shelves are removable, which allows the shelves to be cleaned properly.

Asbestos door gasket

- The asbestos door gasket provides an almost airtight seal between the door and the cabinet.
- This seal prevents the outside air from entering the cabinet and thus, creating an isolated hot environment inside the cabinet without being interrupted by the external environment.

L-shaped thermometer

- A thermometer is placed on the top part of the outer wall of the incubator.
- One end of the thermometer provided with gradations remains outside of the incubator so that temperature can be read easily.
- The next end with the mercury bulb is protruded slightly into the chamber of the incubator.

HEPA filters

- Some advanced incubators are also provided with HEPA filters to lower the possible contamination created due to airflow.
- An air-pump with filters creates a closed-loop system so that the air flowing inside the incubator generates less contamination.

Humidity and gas control

- The CO₂ incubators are provided with a reservoir underneath the chamber that contains water.
- The water is vapourised to maintain the relative humidity inside the chamber.
- Similarly, these incubators are also provided with gas chambers to give the desired concentration of CO₂ inside the incubator.

Principle/ Working of Incubator

- An incubator is based on the principle that microorganisms require a particular set of parameters for their growth and development.
- All incubators are based on the concept that when organisms are provided with the optimal condition of temperature, humidity, oxygen, and carbon dioxide levels, they grow and divide to form more organisms.
- In an incubator, the thermostat maintains a constant temperature that can be read from the outside via the thermometer.
- The temperature is maintained by utilizing the heating and no-heating cycles.
- During the heating cycle, the thermostat heats the incubator, and during the no-heating period, the heating is stopped, and the incubator is cooled by radiating heat to the surrounding.
- Insulation from the outside creates an isolated condition inside the cabinet, which allows the microbes to grow effectively.
- Similarly, other parameters like humidity and airflow are also maintained through different mechanisms that create an environment similar to the natural environment of the organisms.
- Similarly, they are provided with adjustments for maintaining the concentration of CO₂ to balance the pH and humidity required for the growth of the organisms.

- Variation of the incubator like a shaking incubator is also available, which allows for the continuous movement of the culture required for cell aeration and solubility studies.

Procedure for running an incubator

Once the cultures of organisms are created, the culture plates are to be placed inside an incubator at the desired temperature and required period of time. In most clinical laboratories, the usual temperature to be maintained is 35–37°C for bacteria.

The following are the steps to be followed while running an incubator:

1. Before using the incubator, it should be made sure that no remaining items are present in the incubator from the previous cycles. However, in some cases, if the same incubator is being used for multiple organisms, and they require the same set of parameters, they can be placed together in the same incubator.
2. The door of the incubator is then kept closed, and the incubator is switched on. The incubator has to be heated up to the desired temperature of the growth of the particular organism. The thermometer can be used to see if the temperature has reached.
3. In the meantime, if the organism requires a particular concentration of CO₂ or a specific humidity, those parameters should also be set in the incubator.
4. Once all the parameters are met, the petri dish cultures are placed on the perforated shelves upside down, i.e., media uppermost. This is necessary because if the plates are incubated normally, condensation collects on the surface of the medium and prevents the formation of isolated colonies.
5. If it is necessary to incubate Petri dish cultures for several days, the plates are sealed with adhesive tapes or are placed in plastic bags or plastic food containers.
6. Now, the door is locked, and the plates are kept inside for the required time before taking them out.

Types of incubators

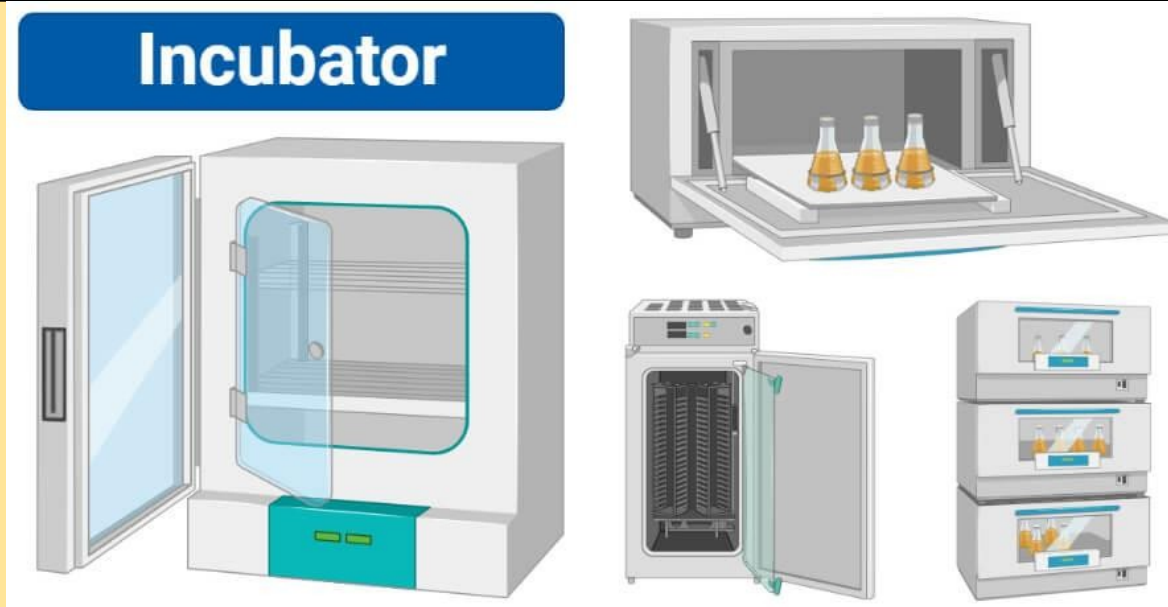

Figure: Some Incubators used in Microbiology Lab. Image created using [bioredner.com](https://www.bioredner.com)

On the basis of the presence of a particular parameter or the purpose of the incubator, incubators are divided into the following types:

Benchtop incubators

- This is the most common type of incubator used in most of the laboratories.
- These incubators are the basic types of incubators with temperature control and insulation.

CO₂ incubators

- CO₂ incubators are the special kinds of incubators that are provided with automatic control of CO₂ and humidity.
- This type of incubator is used for the growth of the cultivation of different bacteria requiring 5-10% of CO₂ concentration.
- For humidity control, water is kept underneath the cabinet of the incubator.

Cooled incubators

- For incubation at temperatures below the ambient, incubators are fitted with modified refrigeration systems with heating and cooling controls.
- This type of incubator is called the cooling incubator.
- In the cooling incubator, the heating and cooling controls should be appropriately balanced.

Shaker incubator

- A thermostatically controlled shaker incubator is another piece of apparatus used to cultivate microorganisms.
- Its advantage is that it provides a rapid and uniform transfer of heat to the culture vessel, and its agitation provides increased aeration, resulting in acceleration of growth.
- This incubator, however, can only be used for broth or liquid **culture media**.

Portable incubator

- Portable incubators are smaller in size and are used in fieldwork, e.g. environmental microbiology and water examination.

Uses of Incubator

Incubators have a wide range of applications in various areas including cell culture, pharmaceutical studies, hematological studies, and biochemical studies.

Some of the uses of incubators are given below:

1. Incubators are used to grow microbial culture or cell cultures.
2. Incubators can also be used to maintain the culture of organisms to be used later.
3. Some incubators are used to increase the growth rate of organisms, having a prolonged growth rate in the natural environment.
4. Specific incubators are used for the reproduction of microbial colonies and subsequent determination of biochemical oxygen demand.
5. These are also used for breeding of insects and hatching of eggs in zoology.
6. Incubators also provide a controlled condition for sample storage before they can be processed in the laboratories.

Precautions

The following precautions are to be followed while running an incubator:

1. As microorganisms are susceptible to temperature change, the fluctuations in temperature of the cabinet by repeatedly opening the door should be avoided.

2. The required parameters growth of the organism should be met before the culture plates are placed inside the cabinet.
3. The plates should be placed upside down with the lid at the bottom to prevent the condensation of water on to the media.
4. The inside of the incubators should be cleaned regularly to prevent the organisms from settling on the shelves or the corners of the incubator.
5. While running the incubator for an extended period of time, sterile water should be placed underneath the shelves to prevent the culture media from drying out.

Water bath

A **water bath** is laboratory equipment made from a container filled with heated water. It is used to incubate samples in water at a constant temperature over a long period of time. Most water baths have a digital or an analogue interface to allow users to set a desired temperature, but some water baths have their temperature controlled by a current passing through a resistor. Utilisations include warming of reagents, melting of substrates or incubation of cell cultures. It is also used to enable certain chemical reactions to occur at high temperature. Water bath is a preferred heat source for heating flammable chemicals instead of an open flame to prevent ignition.^[1] Different types of water baths are used depending on application. For all water baths, it can be used up to 99.9 °C.^{[2][3]} When temperature is above 100 °C, alternative methods such as oil bath, silicone bath or sand bath may be used.

It is not recommended to use water bath with moisture sensitive or pyrophoric reactions.^[5] Do not heat a bath fluid above its flash point.

- Water level should be regularly monitored, and filled with distilled water only.^{[7][8]} This is required to prevent salts from depositing on the heater.
- Disinfectants can be added to prevent growth of organisms.
- Raise the temperature to 90 °C or higher to once a week for half an hour for the purpose of decontamination.
- Markers tend to come off easily in water baths. Use water resistant ones.
- If application involves liquids that give off fumes, it is recommended to operate water bath in fume hood or in a well ventilated area.
- The cover is closed to prevent evaporation and to help reaching high temperatures.
- Set up on a steady surface away from flammable materials.

Types of water bath



A shaking water bath in action

Circulating water baths

Circulating water baths (also called *stirrers* ^[10]) are ideal for applications when temperature uniformity and consistency are critical, such as enzymatic and serologic experiments. Water is thoroughly circulated throughout the bath resulting in a more uniform temperature.

Non-circulating water baths

This type of water bath relies primarily on convection instead of water being uniformly heated. Therefore, it is less accurate in terms of temperature control. In addition, there are add-ons that provide stirring to non-circulating water baths to create more uniform heat transfer.^[4]

Shaking water baths

This type of water bath has extra control for shaking, which moves liquids around. This shaking feature can be turned on or off. In microbiological practices, constant shaking allows liquid-grown cell cultures grown to constantly mix with the air.

Some key benefits of shaking water bath are user-friendly operation via keypad, convenient bath drains, adjustable shaking frequencies, bright LED-display, optional lift-up bath cover, power switch integrated in keypad and warning and cut-off protection for low/high temperature.

Laminar air flow

A Laminar flow hood/cabinet is an enclosed workstation that is used to create a contamination-free work environment through filters to capture all the particles entering the cabinet.

- These cabinets are designed to protect the work from the environment and are most useful for the aseptic distribution of specific **media** and **plate pouring**.
- Laminar flow cabinets are similar to biosafety cabinets with the only difference being that in laminar flow cabinets the effluent air is drawn into the face of the user.
- In a biosafety cabinet, both the sample and user are protected while in the laminar flow cabinet, only the sample is protected and not the user.

Laminar Flow hood / cabinet



Horizontal Laminar Flow Hood Diagram (Cutaway Side View)

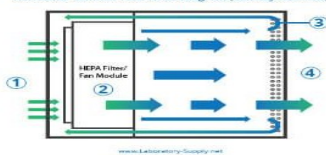

Vertical Laminar Flow Hood Diagram (Cutaway Side View)

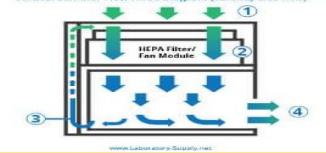

Components/ Parts of Laminar flow hood

A laminar flow cabinet consists of the following parts:

1. Cabinet

- The cabinet is made up of stainless steel with less or no gaps or joints preventing the collection of spores.
- The cabinet provides insulation to the inner environment created inside the laminar flow and protects it from the outside environment.
- The front of the cabinet is provided with a glass shield which in some laminar cabinets opens entirely or in some has two openings for the user's hands to enter the cabinet.

2. Working station

- A flat working station is present inside the cabinet for all the processes to be taken place.
- Culture plates, burner and loops are all placed on the working station where the operation takes place.
- The worktop is also made up of stainless steel to prevent rusting.

3. Filter pad/ Pre-filter

- A filter pad is present on the top of the cabinet through which the air passes into the cabinet.
- The filter pad traps dust particles and some microbes from entering the working environment within the cabinet.

4. Fan/ Blower

- A fan is present below the filter pad that sucks in the air and moves it around in the cabinet.
- The fan also allows the movement of air towards the HEPA filter so that the remaining microbes become trapped while passing through the filter.

5. UV lamp

- Some laminar flow hoods might have a UV germicidal lamp that sterilizes the interior of the cabinet and contents before the operation.
- The UV lamp is to be turned on 15 minutes before the operation to prevent the exposure of UV to the body surface of the user.

6. Fluorescent lamp

- Fluorescent light is placed inside the cabinet to provide proper light during the operation.

7. HEPA filter

- The High-efficiency particulate air filter is present within the cabinet that makes the environment more sterile for the operation.
- The pre-filtered air passes through the filter which traps fungi, bacteria and other dust particles.
- The filter ensures a sterile condition inside the cabinet, thus reducing the chances of contamination.

Principle/ Working of Laminar flow hood

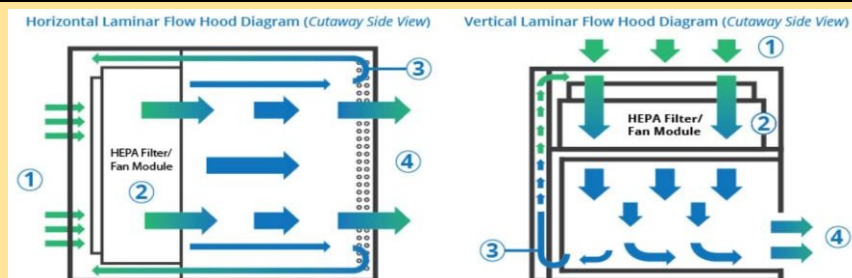

- The principle of laminar flow cabinet is based on the laminar flow of air through the cabinet.
- The device works by the use of inwards flow of air through one or more HEPA filters to create a particulate-free environment.
- The air is taken through a filtration system and then exhausted across the work surface as a part of the laminar flow of the air.
- The air first passes through the filter pad or pre-filter that allows a streamline flow of air into the cabinet.
- Next, the blower or fan directs the air towards the HEPA filters.
- The HEPA filters then trap the bacteria, fungi and other particulate materials so that the air moving out of it is particulate-free air.
- Some of the effluent air then passes through perforation present at the bottom rear end of the cabinet, but most of it passes over the working bench while coming out of the cabinet towards the face of the operator.
- The laminar flow hood is enclosed on the sides, and constant positive air pressure is maintained to prevent the intrusion of contaminated external air into the cabinet.

Procedure for running the laminar flow cabinet

The procedure to be followed while operating a laminar flow cabinet is given below:

1. Before running the laminar flow cabinet, the cabinet should be checked to ensure that nothing susceptible to UV rays is present inside the cabinet.
2. The glass shield of the hood is then closed, and the UV light is switched on. The UV light should be kept on for about 15 minutes to ensure the surface sterilization of the working bench.
3. The UV light is then switched off, and a time period of around 10 minutes is spared before the airflow is switched on.
4. About 5 minutes before the operation begins, the airflow is switched on.
5. The glass shield is then opened, and the fluorescent light is also switched on during the operation.
6. To ensure more protection, the working bench of the cabinet can be sterilized with other disinfectants like 70% alcohol.
7. Once the work is completed, the airflow and fluorescent lamp both are closed and the glass shield is also closed.

Types of laminar flow cabinet

Depending on the direction of movement of air, laminar flow cabinets are divided into two types:

1. Vertical laminar flow cabinet
 - In the vertical flow cabinets, the air moves from the top of the cabinet directly towards the bottom of the cabinet.
 - A vertical airflow working bench does not require as much depth and floor space as a horizontal airflow hood which makes it more manageable and decreases the chances of airflow obstruction or movement of contaminated air downstream.
 - The vertical laminar flow cabinet is also considered safer as it doesn't blow the air directly towards the person carrying out the experiments.
2. Horizontal laminar flow cabinet

- In the horizontal laminar flow cabinets, the surrounding air comes from behind the working bench, which is then projected by the blower towards the HEPA filters.
 - The filtered air is then exhausted in a horizontal direction to the workplace environment.
 - One advantage of this cabinet is that airflow parallel to the workplace cleanses the environment with a constant velocity.
 - The effluent air directly hits the operator, which might reduce the security level of this type of laminar flow cabinets.
-

Uses of Laminar flow hood

The following are some common uses of a laminar flow cabinet in the laboratory:

1. Laminar flow cabinets are used in laboratories for contamination sensitive processes like plant tissue culture.
 2. Other laboratory processes like media plate preparation and culture of organisms can be performed inside the cabinet.
 3. Operations of particle sensitive electronic devices are performed inside the cabinet.
 4. In the pharmaceutical industries, drug preparation techniques are also performed inside the cabinet to ensure a particulate-free environment during the operations.
 5. Laminar flow cabinets can be made tailor-made for some specialized works and can also be used for general lab techniques in the microbiological as well as the industrial sectors.
-

Precautions

While operating the laminar airflow, the following things should be considered:

1. The laminar flow cabinet should be sterilized with the UV light before and after the operation.
2. The UV light and airflow should not be used at the same time.
3. No operations should be carried out when the UV light is switched on.
4. The operator should be dressed in lab coats and long gloves.
5. The working bench, glass shield, and other components present inside the cabinet should be sterilized before and after the completion of work.

Centrifugation- Principle, Types and Applications

- Centrifugation is a technique of separating substances which involves the application of centrifugal force.
 - The particles are separated from a solution according to their size, shape, density, the viscosity of the medium and rotor speed.
-

Principle of Centrifugation



- In a solution, particles whose density is higher than that of the solvent sink (sediment), and particles that are lighter than it float to the top.
- The greater the difference in density, the faster they move. If there is no difference in density (isopycnic conditions), the particles stay steady.
- To take advantage of even tiny differences in density to separate various particles in a solution, gravity can be replaced with the much more powerful “centrifugal force” provided by a centrifuge.
- A centrifuge is a piece of equipment that puts an object in rotation around a fixed axis (spins it in a circle), applying a potentially strong force perpendicular to the axis of spin (outward).
- The centrifuge works using the sedimentation principle, where the centripetal acceleration causes denser substances and particles to move outward in the radial direction.
- At the same time, objects that are less dense are displaced and move to the center.
- In a laboratory centrifuge that uses sample tubes, the radial acceleration causes denser particles to settle to the bottom of the tube, while low-density substances rise to the top.



Types of Centrifuge

LOW-SPEED CENTRIFUGE

- 1) Most laboratories have a standard low-speed centrifuge used for routine sedimentation of heavy particles
 - 2) The low-speed centrifuge has a maximum speed of 4000-5000rpm
 - 3) These instruments usually operate at room temperatures with no means of temperature control.
 - 4) Two types of rotors are used in it,
 - Fixed angle
 - Swinging bucket.
 - 5) It is used for sedimentation of red blood cells until the particles are tightly packed into a pellet and supernatant is separated by decantation.
-

HIGH-SPEED CENTRIFUGES

1. High-speed centrifuges are used in more sophisticated biochemical applications, high speeds and temperature control of the rotor chamber are essential.
2. The high-speed centrifuge has a maximum speed of 15,000 – 20,000 RPM
3. The operator of this instrument can carefully control speed and temperature which is required for sensitive biological samples.
4. Three types of rotors are available for high-speed centrifugation-
 - Fixed angle
 - Swinging bucket
 - Vertical rotors

ULTRACENTRIFUGES

1. It is the most sophisticated instrument.
2. Ultracentrifuge has a maximum speed of 65,000 RPM (100,000's x g).
3. Intense heat is generated due to high speed thus the spinning chambers must be refrigerated and kept at a high vacuum.
4. It is used for both preparative work and analytical work.

Types of Centrifugation

1. Differential Pelleting (differential centrifugation)

- It is the most common type of centrifugation employed.
- Tissue such as the liver is homogenized at 32 degrees in a sucrose solution that contains buffer.
- The homogenate is then placed in a centrifuge and spun at constant centrifugal force at a constant temperature.
- After some time a sediment forms at the bottom of a centrifuge called pellet and an overlying solution called supernatant.
- The overlying solution is then placed in another centrifuge tube which is then rotated at higher speeds in progressing steps.

DIFFERENTIAL CENTRIFUGATION

Repeated centrifugation at progressively higher speeds will fractionate cell homogenates into their components.

Centrifugation separates cell components on the basis of size and density. The larger and denser components experience the greatest centrifugal force and move most rapidly. They sediment to form a pellet at the bottom of the tube, while smaller, less dense components remain in suspension above, a portion called the supernatant.

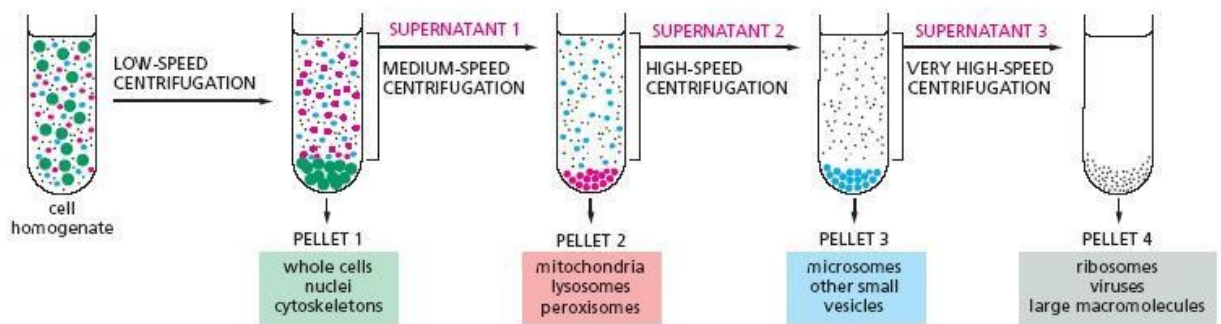

2. Density Gradient Centrifugation

- This type of centrifugation is mainly used to purify viruses, ribosomes, membranes, etc.
- A sucrose density gradient is created by gently overlaying lower concentrations of sucrose on higher concentrations in centrifuge tubes
- The particles of interest are placed on top of the gradient and centrifuge in ultracentrifuges.
- The particles travel through the gradient until they reach a point at which their density matches the density of surrounding sucrose.
- The fraction is removed and analyzed.

3. Rate-Zonal Density-Gradient Centrifugation

- Zonal centrifugation is also known as band or gradient centrifugation
- It relies on the concept of sedimentation coefficient (i.e. movement of sediment through the liquid medium)
- In this technique, a density gradient is created in a test tube with sucrose and high density at the bottom.
- The sample of protein is placed on the top of the gradient and then centrifuged.
- With centrifugation, faster-sedimenting particles in sample move ahead of slower ones i.e. sample separated as zones in the gradient.
- The protein sediment according to their sedimentation coefficient and the fractions are collected by creating a hole at the bottom of the tube.

4. Isopycnic Centrifugation

- The sample is loaded into the tube with the gradient-forming solution (on top of or below pre-formed gradient, or mixed in with self-forming gradient)
- The solution of the biological sample and cesium salt is uniformly distributed in a centrifuge tube and rotated in an ultracentrifuge.
- Under the influence of centrifugal force, the cesium salts redistribute to form a density gradient from top to bottom.
- Particles move to point where their buoyant density equals that part of gradient and form bands. This is to say the sample molecules move to the region where their density equals the density of gradient.
- It is a “true” equilibrium procedure since depends on buoyant densities, not velocities

Eg: CsCl, NaI gradients for macromolecules and nucleotides – “self-forming” gradients under centrifugal force.

Density Gradient Centrifugation

Separation of components of a sample on the basis of their density, in a density gradient, in a centrifuge, according to the centrifugal force they experience.

2 principle types

Rate zonal centrifugation

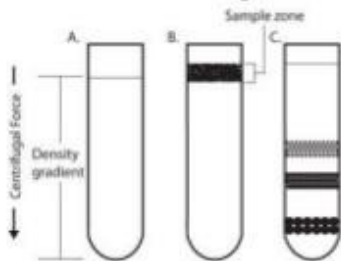

- Separation of cells/particles based on the differences in size, shape & density.
- involves carefully layering a sample solution on top of preformed liquid density gradient
- centrifuged until the desired degree of separation is achieved
- Time dependent

Isopycnic Separation

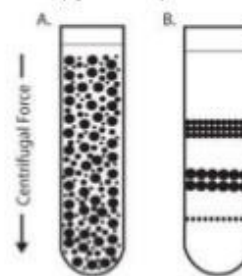

- Separation of cells/particles solely by their density, not by shapes, sizes & time
- Particle size only affect the rate at which particles move until their density is the same as the surrounding gradient medium.
- Used to separate particles of similar size but of different density.

Applications of Centrifugation

- To separate two miscible substances
- To analyze the hydrodynamic properties of macromolecules
- Purification of mammalian cells
- Fractionation of subcellular organelles (including membranes/membrane fractions) Fractionation of membrane vesicles
- Separating chalk powder from water
- Removing fat from milk to produce skimmed milk
- Separating particles from an air-flow using cyclonic separation
- The clarification and stabilization of wine
- Separation of urine components and blood components in forensic and research laboratories
- Aids in the separation of proteins using purification techniques such as salting out, e.g. ammonium sulfate precipitation.

pH meters

Who invented the pH meter?

Who do we have to thank for this clever stuff? First, Nobel-Prize winning German chemist Fritz Haber (1868–1934) and his student Zygmunt Klemensiewicz (1886–1963) developed the glass electrode idea in 1909. The modern, electronic pH meter was invented about a quarter century later, around 1934/5, when American chemist Arnold Beckman (1900–2004) figured out how to hook up a glass electrode to an amplifier and voltmeter to make a much more sensitive instrument

A typical pH meter has two basic components: the meter itself, which can be a moving-coil meter (one with a pointer that moves against a scale) or a digital meter (one with a numeric display), and either one or two probes that you insert into the solution you're testing. To make electricity flow through something, you have to create a complete electrical circuit; so, to make electricity flow through the test solution, you have to put two electrodes (electrical terminals) into it. If your pH meter has two probes (like the one in the photo at the top of this article), each one is a separate electrode; if you have only one probe, both of the two electrodes are built inside it for simplicity and convenience.

The electrodes aren't like normal electrodes (simple pieces of metal wire); each one is a mini chemical set in its own right. The electrode that does the most important job, which is called the glass electrode, has a silver-based electrical wire suspended in a solution of potassium chloride, contained inside a thin bulb (or membrane) made from a special glass containing metal salts (typically compounds of sodium and calcium). The other electrode is called the reference electrode and has a potassium chloride wire suspended in a solution of potassium chloride.

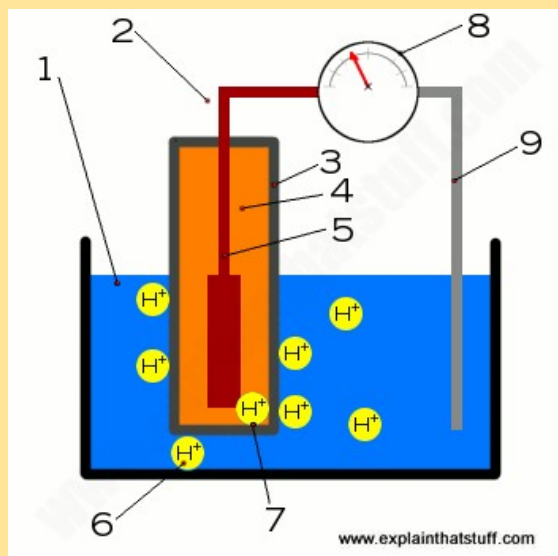

Artwork: Key parts of a pH meter: (1) Solution being tested; (2) Glass electrode, consisting of (3) a thin layer of silica glass containing metal salts, inside which there is a potassium chloride

solution (4) and an internal electrode (5) made from silver/silver chloride. (6) Hydrogen ions formed in the test solution interact with the outer surface of the glass. (7) Hydrogen ions formed in the potassium chloride solution interact with the inside surface of the glass. (8) The meter measures the difference in voltage between the two sides of the glass and converts this "potential difference" into a pH reading. (9) Reference electrode acts as a baseline or reference for the measurement—or you can think of it as simply completing the circuit.

The potassium chloride inside the glass electrode (shown here colored orange) is a neutral solution with a pH of 7, so it contains a certain amount of hydrogen ions (H^+). Suppose the unknown solution you're testing (blue) is much more acidic, so it contains a lot more hydrogen ions. What the glass electrode does is to measure the difference in pH between the orange solution and the blue solution by measuring the difference in the voltages their hydrogen ions produce. Since we know the pH of the orange solution (7), we can figure out the pH of the blue solution.

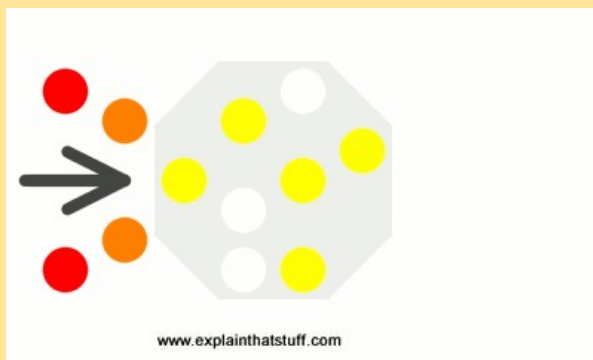

How does it all work? When you dip the two electrodes into the blue test solution, some of the hydrogen ions move toward the outer surface of the glass electrode and replace some of the metal ions inside it, while some of the metal ions move from the glass electrode into the blue solution. This ion-swapping process is called ion exchange, and it's the key to how a glass electrode works. Ion-swapping also takes place on the inside surface of the glass electrode from the orange solution. The two solutions on either side of the glass have different acidity, so a different amount of ion-swapping takes place on the two sides of the glass. This creates a different degree of hydrogen-ion activity on the two surfaces of the glass, which means a different amount of electrical charge builds up on them. This charge difference means a tiny voltage (sometimes called a potential difference, typically a few tens or hundreds of millivolts) appears between the two sides of the glass, which produces a difference in voltage between the silver electrode (5) and the reference electrode (8) that shows up as a measurement on the meter.

Although the meter is measuring voltage, what the pointer on the scale (or digital display) actually shows us is a pH measurement. The bigger the difference in voltage between the orange (inside) and blue (outside) solutions, the bigger the difference in hydrogen ion activity between. If there is more hydrogen ion activity in the blue solution, it's more acidic than the orange solution and the meter shows this as a lower pH; in the same way, if there's less hydrogen ion activity in the blue solution, the meter shows this as a higher pH (more alkaline).

Making accurate pH measurements

For pH meters to be accurate, they have to be properly calibrated (the meter is accurately translating voltage measurements into pH measurements), so they usually need testing and adjusting before you start to use them. You calibrate a pH meter by dipping it into buffers (test solutions of known pH) and adjust the meter accordingly. Another important consideration is that pH measurements made this way depend on temperature. Some meters have built-in thermometers and automatically correct their own pH measurements as the temperature changes; those are best if fluctuations in temperature are likely to occur while you're making a number of different measurements. Alternatively, you can correct the pH measurement yourself, or allow for it by calibrating your instrument and making pH measurements at broadly the same temperature.

conductivity meter

A conductivity meter measures the amount of electrical current or conductance in a solution. Conductivity is useful in determining the overall health of a natural water body. It is also a way to measure changes in wastewater procedures at water treatment plants. Conductivity meters are common in any water treatment or monitoring situation, as well as in environmental laboratories. According to the Environmental Protection Agency, a good conductivity meter costs about \$250.

How a Conductivity Meter Works

The meter is equipped with a probe, usually handheld, for field or on-site measurements. After the probe is placed in the liquid to be measured, the meter applies voltage between two electrodes inside the probe. Electrical resistance from the solution causes a drop in voltage, which is read by the meter. The meter converts this reading to milli- or micromhos or milli- or microSiemens per centimeter. This value indicates the total dissolved solids. Total dissolved solids is the amount of solids that can pass through a glass-fiber filter.

Conductivity Basics

Conductivity is the electrical current in a solution, but that value depends on the liquid's ionic strength. It also relies on which ions are present, in what concentration and in what form, such as what state of oxidation or mobility the ions are in. Ions carry a negative or positive electrical charge: anions are negative and cations are positive. In natural water bodies, the ions that contribute to high conductivity result from dissolved minerals and salts.

Temperature Dependence

The reading of a conductivity meter is usually without a temperature correlation. Since ionic strength, and therefore conductance, is temperature-dependent, the reading may be inaccurate. Thus, many conductivity meters have a specific conductance measurement as well. When in the specific conductance mode, the meter reads the conductivity of the solution at 25 degrees Celsius, not at the actual temperature. This results in a more standardized reading.

Salinity and Total Dissolved Solids

Salinity is the amount of dissolved salts in a solution. Conductivity meters equipped with a salinity option internally convert the conductivity reading to one of salinity. Fresh water bodies should have a much lower salinity concentration than ocean water, which is estimated between 20 and 30 parts per trillion, according to Washington State's Department of Ecology. Total dissolved solids can be determined by multiplying the conductivity measured in microSeimens by a factor of 0.67.

Calibration

Calibration leads to a more accurate reading. To calibrate a meter, follow the instructions for that meter; in general, the steps are easy and standardized. The meter usually has a menu item that allows you to enter the calibration mode or a setting on the side that you can adjust with a small screwdriver or tool. Place the probe in a solution with a known conductivity value and temperature and set the meter to that conductivity. Sometimes several standards are required. The Environmental Protection Agency's EPA 120.1 outlines a standardized analytical procedure for calibrating and measuring using a conductivity meter.

Lyophilizer vs. Freeze Dryer

What is a lyophilizer? How does it work?

Lyophilizer and **freeze dryer** are synonymous names for the same equipment. A lyophilizer executes a water removal process typically used to preserve perishable materials, to extend shelf life or make the material more convenient for transport. Lyophilizers work by freezing the material, then reducing the pressure and adding heat to allow the frozen water in the material to sublimate.

A Lyophilizer's 3 Primary Stages

A lyophilizer functions in three phases, with the first and most critical being the freezing phase. Proper lyophilization, otherwise known as freeze drying, can reduce drying times by 30%.

Freezing Phase

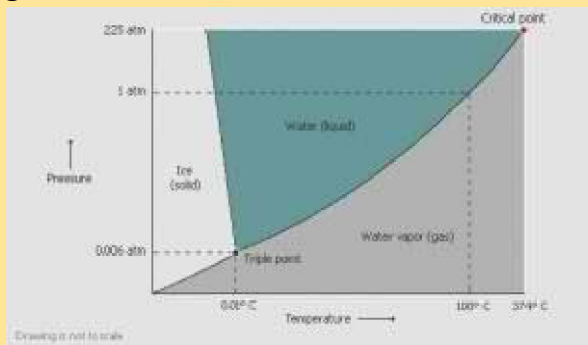

A lyophilizer uses various methods to freeze the product. Freezing can be done in a freezer, a chilled bath (shell freezer), or on a shelf in the lyophilizer. The lyophilizer cools the material

below its triple point to ensure that sublimation, rather than melting, will occur. This preserves the material's physical form.

A lyophilizer most easily freeze dries large ice crystals, which can be produced by slow freezing or annealing. However, with biological materials, when crystals are too large they may break the cell walls, and that leads to less-than-ideal freeze drying results. To prevent this, the freezing is done rapidly. For materials that tend to precipitate, annealing can be used. This process involves fast freezing, then raising the product temperature to allow the crystals to grow.

Primary Drying (Sublimation) Phase

A lyophilizer's second phase is primary drying (sublimation), in which the pressure is lowered and heat is added to the material in order for the water to sublimate. The lyophilizer's vacuum speeds sublimation. The lyophilizer's cold condenser provides a surface for the water vapor to adhere and solidify. The condenser also protects the vacuum pump from the water vapor. About 95% of the water in the material is removed in this phase. Primary drying can be a slow process. Too much heat can alter the structure of the material.

Secondary Drying (Adsorption) Phase

A lyophilizer's final phase is secondary drying (adsorption), during which the ionically-bound water molecules are removed. By raising the temperature higher than in the primary drying phase, the bonds are broken between the material and the water molecules. Freeze dried materials retain a porous structure. After the lyophilizer completes its process, the vacuum can be broken with an inert gas before the material is sealed. Most materials can be dried to 1-5% residual moisture.

Problems To Avoid While Using a Lyophilizer

- Heating the product too high in temperature can cause melt-back or product collapse
- Condenser overload caused by too much vapor hitting the condenser.
 - Too much vapor creation
 - Too much surface area
 - Too small a condenser area
 - Insufficient refrigeration
- Vapor choking – the vapor is produced at a rate faster than it can get through the vapor port, the port between the product chamber and the condenser, creating an increase in chamber pressure. **Important Lyophilizer Terms**

Here are a few important terms related to lyophilizers. For a comprehensive list see our **freeze drying terminology page**.

Eutectic Point or Eutectic Temperature

Is the point at which the product only exists in the solid phase, representing the minimum melting temperature. Not all products have a eutectic point or there may be multiple eutectic points.

Critical Temperature

During freeze drying, the maximum temperature of the product before its quality degrades by melt-back or collapse.

McIntosh and Filde's anaerobic jar

McIntosh and Filde's anaerobic jar is an instrument used in the production of an anaerobic environment. This method of *anaerobiosis* as others is used to culture bacteria which die or fail to grow in presence of oxygen (*anaerobes*).

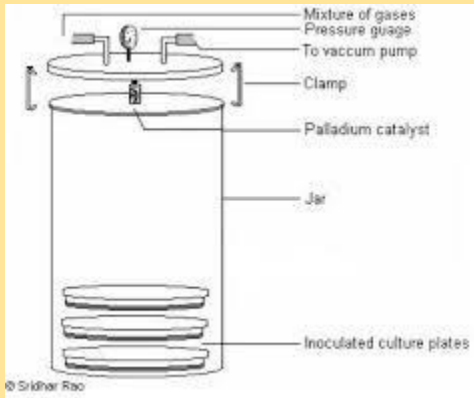

Construction The jar, about 20"×12.5" is made up of a metal. Its parts are as follows:

1. The body made up of metal (airtight)
2. The lid, also metal can be placed in an airtight fashion
3. A screw going through a curved metal strip to secure and hold the lid in place
4. A thermometer to measuring the internal temperature
5. A pressure gauge to measuring the internal pressure (or a side tube is attached to a manometer)
6. Another side tube for evacuation and introduction of gases (to a gas cylinder or a vacuum pump)
7. A wire cage hanging from the lid to hold a catalyst that makes hydrogen react to oxygen without the need of any ignition source

Method of use

- First:
 1. **The culture:** The culture media are placed inside the jar, stacked up one on the other, and
 2. **Indicator system:** *Pseudomonas aeruginosa*, inoculated on to a nutrient agar plate is kept inside the jar along with the other plates. This bacteria need oxygen to grow (*aerobic*). A growth free culture plate at the end of the process indicates a successful anaerobiosis. However, *P. aeruginosa* possesses a denitrification pathway. If nitrate is present in the media, *P. aeruginosa* may still grow under anaerobic conditions.
- Second: $\frac{6}{7}$ th of the air inside is pumped out and replaced with either unmixed Hydrogen or a 10%CO₂+90%H₂ mixture. The catalyst (Palladium) acts and the oxygen is used up in

forming water with the hydrogen. The manometer registers this as a fall in the internal pressure of the jar.

- Third: Hydrogen is pumped in to fill up the jar so that the pressure inside equals atmospheric pressure. The jar is now incubated at desired temperature settings.

Biosensors

- Analytical devices that consists a combination of biological detecting elements like sensor system and a transducer is termed as **biosensor**.
- Biosensors can be defined as self-sufficient integrated devices that has capacity to provide specific qualitative or semi-quantitative analytical information using a biological recognition element which is in direct-spatial contact with a transductional element.
- In simple words, biosensors are analytical devices that detects changes in biological processes and transform the biological data into electrical signal.
- The main features of biosensors are:
 - **Stability**
 - **Economical**
 - **Sensitivity**
 - **Reproducibility**

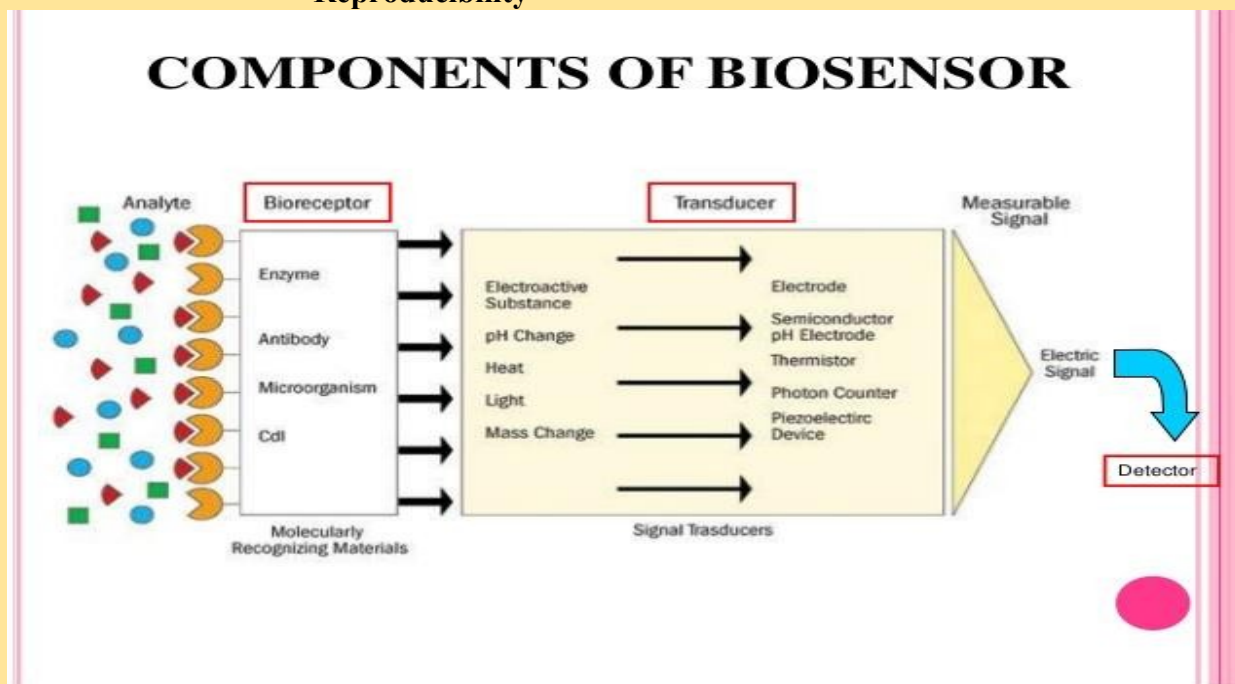

Components of biosensor:

- The block diagram of the biosensor consists of three segments namely, **sensor, transducer, and electrical circuit.**

- **i. Sensor or detector:** The first segment is the sensor or detector which is a biological component. It is a biochemical receptor. It interacts with the analyte and signals the change in its composition as an electrical signal.
- **ii. Transducer:** The second segment is the transducer and it is a physical component which amplifies the biochemical signal received from the detector, alters the resulting signal into electrical and displays it in an attainable way.
- **iii. Electrical circuit:** It is the associated part which consists of a Signal Conditioning Unit, a Processor or Micro-controller and a Display Unit.

Principle of Biosensors:

- Biosensors work on the principle of signal transduction and biorecognition of an element.
- All the biological materials including enzyme, antibody, nucleic acid, hormone, organelle or whole cell can be used as a sensor or detector in a device. But the desired bio-receptor is usually a specific deactivated enzyme.
- The deactivated enzyme is placed in proximity to the transducer.
- The tested analyte links to the specific enzyme (bio-receptor) and induces a change in the biochemical property of the enzyme. The change in turn gives an electronic response through an electroenzymatic approach.
- Electroenzymatic process is the chemical process of converting the enzymes into corresponding electrical signals with the aid of a transducer.
- Now, the outcome from the transducer i.e. electrical signal is a direct representation of the biological material (i.e. analyte and enzyme in this case) being measured.
- The electrical signal is usually converted into a physical display for its proper analysis and representation.

Working principle of biosensors:

- The union of a biological sensitive element and a transducer is responsible for converting the biological material into a corresponding electrical response in the form of a signal.
- The output of the transducer will be either current or voltage, depending on the type of enzyme.
- If the output is voltage, then it is fine. But if the output is current, then this current needs to be converted into equivalent voltage (using an Op-Amp based current-to-voltage converter) before proceeding further.
- The output voltage signal is generally very low in amplitude and is superimposed on a high frequency noise signal.
- Thus, the signal is amplified (using an Op-Amp based amplifier) and then it is passed through a Low Pass RC Filter.
- A Signal Processing Unit or a Signal Conditioning Unit is responsible for performing this process of amplifying and filtering the signal.
- The output of the signal processing unit is termed as an analog signal. This output is equivalent to the biological quantity being measured.

- The analog signal can be exhibited directly on an LCD display but usually, this analog signal is passed to a Microcontroller, where the analog signal is converted into digital signal. This is done since it is easy to analyse, process or store a digital signal.

Types:

- On the basis of sensor device as well as the biological material the biosensors are classified as:
 - 1. Electrochemical biosensors
 - 2. Calorimetric/Thermal detection biosensors
 - 3. Optical biosensors
 - 4. Piezo-electric biosensors
 - 5. Resonant biosensors

1. Electrochemical biosensors:

- Generally, electrochemical biosensor works on the principle that many enzyme catalysis reactions consumes or generates ions or electrons causing some change in electrical properties of the solution which can be detected and used as a measuring parameter.
- For example some biological compounds such as glucose, urea, cholesterol, etc.) are not electroactive, so the combination of reactions by this biosensor produce an electroactive element. This electroactive element results in change of current intensity which is proportional to the concentration of analyte.
- An electrochemical biosensor uses an electrochemical cell with electrodes of different dimension and modifications.
- Three kinds of electrodes are generally used-
 - Working electrode
 - Reference electrode
 - Counter or Auxiliary electrode
- It is the working electrode where reaction occurs between electrode substrate and analyte.

Types of electrochemical biosensors

- Electrochemical biosensors are classified into three types:
 - **Amperometric Biosensors**
 - **Potentiometric Biosensors**
 - **Conductimetric Biosensors**
- **1. Amperometric Biosensors**
 - The Bioelectrochemical reaction in this biosensors generate measurable amount of current which is directly proportional to the substrate concentration.
 - The first generation amperometric biosensors use the Clark oxygen electrode which determines the reduction of O₂ present in the analyte solution.
 - Determination of glucose using glucose oxidase enzyme is a redox reaction which is an example of Amperometric biosensors.

- This first generation biosensors depend on the dissolved O₂ to measure the concentration analyte. However, as modification in second generation biosensors, a mediators is being used.
- This mediators transfer the electrons produced by the bioelectrochemical reaction directly to the electrode instead of reducing O₂ dissolved in analyte solution.
- Nowadays, the electrodes remove the electrons without the aid of mediators and are coated with electrically conducting organic salts.
- **2. Potentiometric biosensors:**
 - Potentiometric biosensors use the ion-selective electrodes to convert the biological reaction to electronic response.
 - Most commonly used electrodes are pH meter glass electrodes (for cations glass pH electrodes coated with a gas selective membrane for CO₂, NH or H₂S.) or solid state electrodes.
 - Biosensors detects and measures the ions or electrons generated in many reactions, very weak buffer solutions are used in this case.
 - Gas sensing electrodes detect and measure the amount of gas produced.
- **3. Conductimetric biosensors:**
 - These biosensors measure electrical conductance/ resistance of the solution.
 - Conductance measurement have comparatively low sensitivity.
 - Electrical field is generated by use of sinusoidal (ac) voltage which serves in reducing unwanted effects such as:
 - Faradaic processes
 - Double layer charging
 - Concentration polarization

2. Calorimetric/Thermal detection biosensors:

- Most of the enzyme catalysed reactions are exothermic in nature.
- Calorimetric biosensors measure the change in temperature of analyte solution following enzyme action and interpret it in terms of analyte concentration in the solution.
- The analyte solution is passed through a small packed bed column consisting immobilized enzyme.
- The temperature of the solution is measured just before the entry of the solution into the column, and just as it leaves the column using separate thermistors.
- It is the most usually applicable type of biosensor and can also be used for turbid and colourful solutions.
- There are demerits such as:
 - The biggest demerit is to maintain the temperature of the sample stream say + or -0.01°C.
 - Low range and sensitivity.

3. Optical biosensors:

- Both catalytic and affinity reactions are measured by this biosensor.
- The products generated during the catalytic reactions cause a change in fluorescence that is measured by the biosensor.
- In other way, biosensors measure the change induced in the intrinsic optical properties of the biosensor surface due to loading on it of di-electric molecules like protein.
- A most advanced biosensor involving luminescence uses luciferase enzyme for detection of bacteria in food or clinical samples.
- In the presence of O₂, luciferase takes up the ATP released from the lysis of bacteria to produce light which is detected and measured by biosensor.

4. Piezo-electric biosensors:

- In these biosensors, the surface is coated with antibodies which binds to the complementary antigen present in the sample solution.
- This results in increased mass which decreases their vibrational frequency, this alteration/change is used to determine the amount of antigen present in the sample solution.

4. Resonant biosensors:

- The vibrations of the electron cloud in a molecule is termed as resonant biosensors.
- These plasmons oscillate at a particular frequency characteristic of the material.
- The oscillations in surface plasmons are confined to the surface of the material.
- Generally, gold or silver surfaces are preferred for the SPR based biosensors.
- When electromagnetic radiation falls on the metal surface, at a particular angle of incidence, the frequency of the electromagnetic radiation matches the frequency of vibrations resulting in resonance.
- The resonant angle depends on the refractive index of the medium.
- The refractive index in turn is determined by the local mass density on the metal surface.
- If the surface of the metal film is modified with the antibody/receptor i.e. capture molecule, then specific binding occurs between the capture molecule on addition of the sample and its ligand leading to an alteration in mass and hence change in resonant angle.
- These biosensors are employed to understand the functional aspects of human immune deficiency virus (HIV) both qualitatively and quantitatively.
- The major merits of these biosensors are rapid measurements and relatively high sensitivity,
- The major demerit is that it cannot be used to detect and measure the turbid and coloured solutions. In few cases, ligands may interfere with the binding.

Metabolic Shaker

A **shaker** is a piece of laboratory equipment used to mix, blend, or agitate substances in a tube or flask by shaking them. It is mainly used in the fields of chemistry and biology. A shaker contains an oscillating board that is used to place the flasks, beakers, or test tubes. Although the magnetic stirrer has lately come to replace the shaker, it is still the preferred choice of equipment when dealing with large volume substances or when simultaneous agitation is required.

Types of shakers

Vortex shaker

Invented by Jack A. Kraft and Harold D. Kraft in 1962, a vortex shaker is a usually small device used to shake or mix small vials of liquid substance. Its most standout characteristic is that it works by the user putting a vial on the shaking platform and turning it on; thus, the vial is shaken along with the platform. A vortex shaker is very variable in terms of speed adjustment, for the shaking speed can be continuously changed while shaking by turning a switch.^[2]

Platform shaker

A platform shaker has a table board that oscillates horizontally. The liquids to be stirred are held in beakers, jars, or erlenmeyer flasks that are placed over the table or, sometimes, in test tubes or vials that are nested into holes in the plate.^[3] Platform shakers can also be combined with other systems like rotating mixers for small systems and have been designed to be manufactured in laboratories themselves with open source scientific equipment.^[4]

Orbital shaker

An orbital shaker has a circular shaking motion with a slow speed (25-500 rpm). It is suitable for culturing microbes, washing blots, and general mixing. Some of its characteristics are that it does not create vibrations, and it produces low heat compared to other kinds of shakers, which makes it ideal for culturing microbes. Moreover, it can be modified by placing it in an incubator to create an incubator shaker due to its low temperature and vibrations.

Incubator shaker

An incubator shaker (or thermal shaker) can be considered a mix of an incubator and a shaker. It has an ability to shake while maintaining optimal conditions for incubating microbes or DNA replications. This equipment is very useful since, in order for a cell to grow, it needs oxygen and nutrients that require shaking so that they can be distributed evenly around the culture.

Anyone employing an incubator shaker (thermal shaker) to grow yeast or bacteria in the laboratory needs to beware that under the usual conditions encountered in the lab, the rate at which oxygen diffuses from the gaseous phase into the shaken liquid phase is too slow to keep up with the rate at which the oxygen is consumed by for example E coli dividing every half hour or S cerevisiae dividing every hour. If the investigator measure the oxygen in the shake flask on the shaker -- polarographically, for example -- at mid-exponential phase of growth, the dissolved oxygen concentration will turn out to be zero.